



# P 18 MK2 PROFILE

DMX Protokoll | DMX Chart

Version 1.10

Software >= 1.1.0

## Inhalt / Content

Deutsch

<b>1.0 P18 Profile MK2 Modelle</b> .....	<b>03</b>
<b>2.0 Menü-Übersicht</b> .....	<b>03</b>
<b>3.0 Ansteuerungsmöglichkeiten</b> .....	<b>06</b>
3.1 DMX .....	06
3.1.1 Übersicht DMX-Modi P18 MK2 Profile .....	06
3.1.2 DMX-Kanalfunktionen P18 Profile MK2 Profile .....	08
3.1.3 Steuerkanal .....	15
3.1.4 Sparkle Effekt, Sparklegeschwindigkeit .....	15
3.1.5 Autofokus .....	15
3.2 Artnet .....	15
3.3 Streaming ACN .....	15
3.4 Wireless-DMX .....	16
3.5 RDM .....	16
3.5.1 RDM-UID .....	16
3.5.2 RDM-PIDs .....	16
3.5.3 Standard RDM-Parameter-IDs .....	16
3.5.4 Herstellerspezifische RDM-Parameter-IDs .....	17
3.5.5 RDM-Sensoren-IDs .....	17
<b>4.0 P18 Profile MK2 models</b> .....	<b>19</b>
<b>5.0 Menu navigation</b> .....	<b>19</b>
<b>6.0 Control options</b> .....	<b>22</b>
6.1 DMX .....	22
6.1.1 Operating modes P18 MK2 Profile .....	22
6.1.2 DMX channel functions P18 Profile MK2 Profile .....	24
6.1.3 Control channel .....	31
6.1.4 Sparkle effect, sparkle speed .....	31
6.1.5 Auto focus .....	31
6.2 Artnet .....	31
6.3 Streaming ACN .....	31
6.4 Wireless-DMX .....	32
6.5 RDM .....	32
6.5.1 RDM-UID .....	32
6.5.2 RDM-PIDs .....	32
6.5.3 Standard RDM parameter IDs .....	32
6.5.4 Manufacturer specific RDM parameter IDs .....	33
6.5.5 RDM sensor IDs .....	33

English

## 1.0 P18 Profile MK2 Modelle

Der P18 Profile MK2 ist in 3 Modellen verfügbar. Die Modelle unterscheiden sich im Lichtmodul und teilweise in den Farbfiltern und in den CTC-Filtern. Die Unterschiede werden jeweils bei den DMX-Kanalfunktionen angegeben.

- P18 Profile MK2 HP (High Power)
- P18 Profile MK2 HC (High CRI)
- P18 Profile MK2 WW (Warm weiß)

## 2.0 Menü-Übersicht

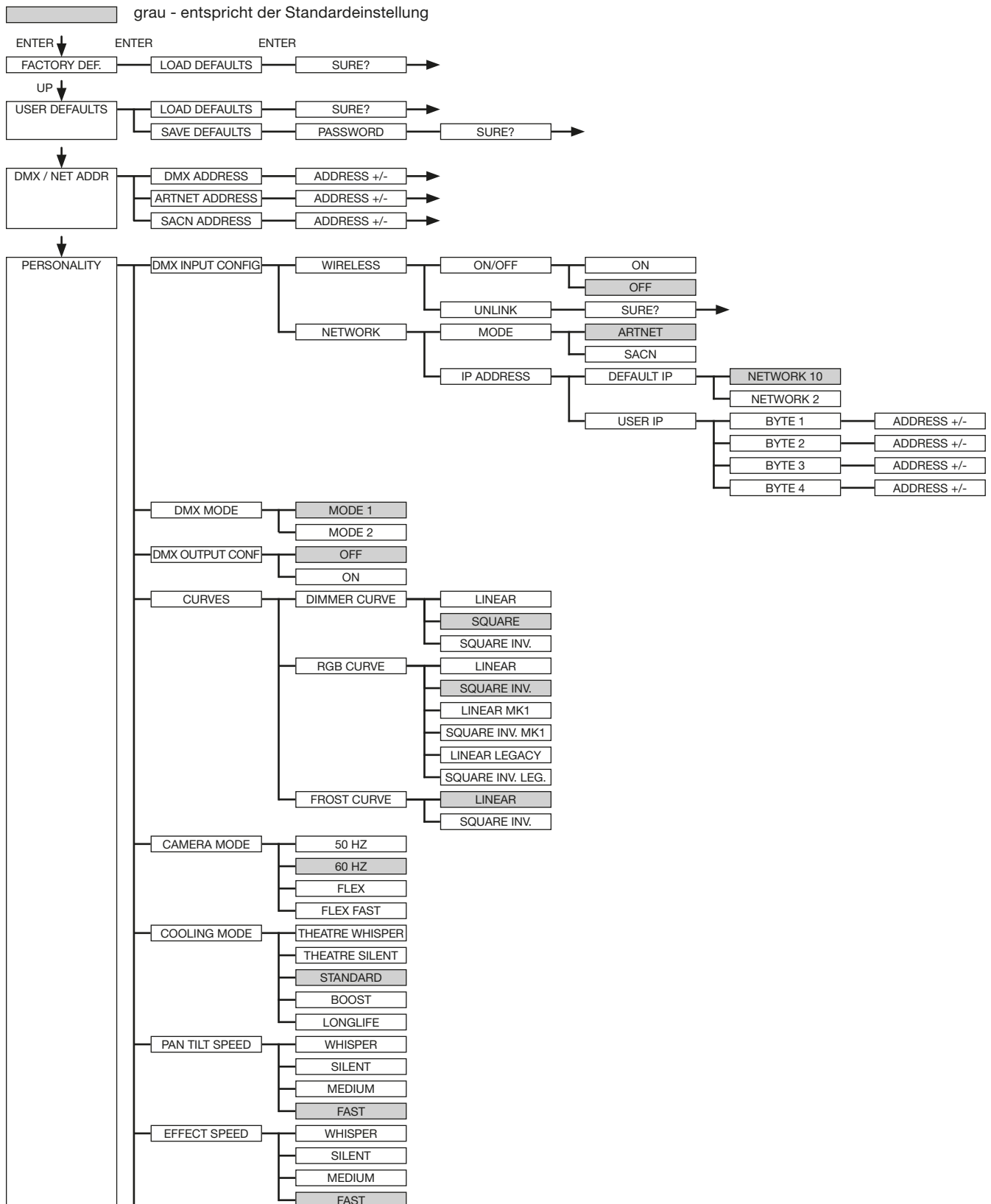

# P 18 MK2 PROFILE

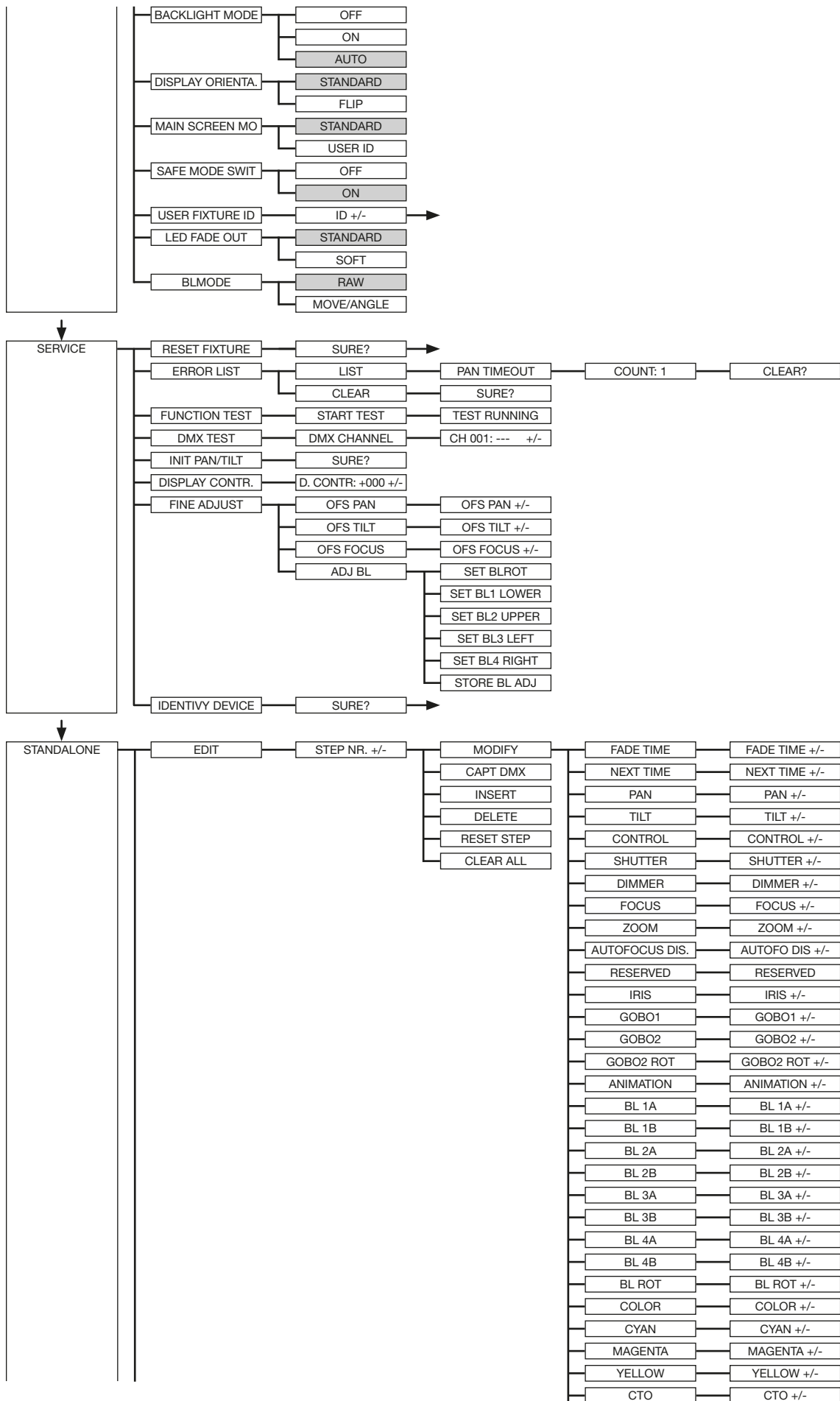

# P18 MK2 PROFILE

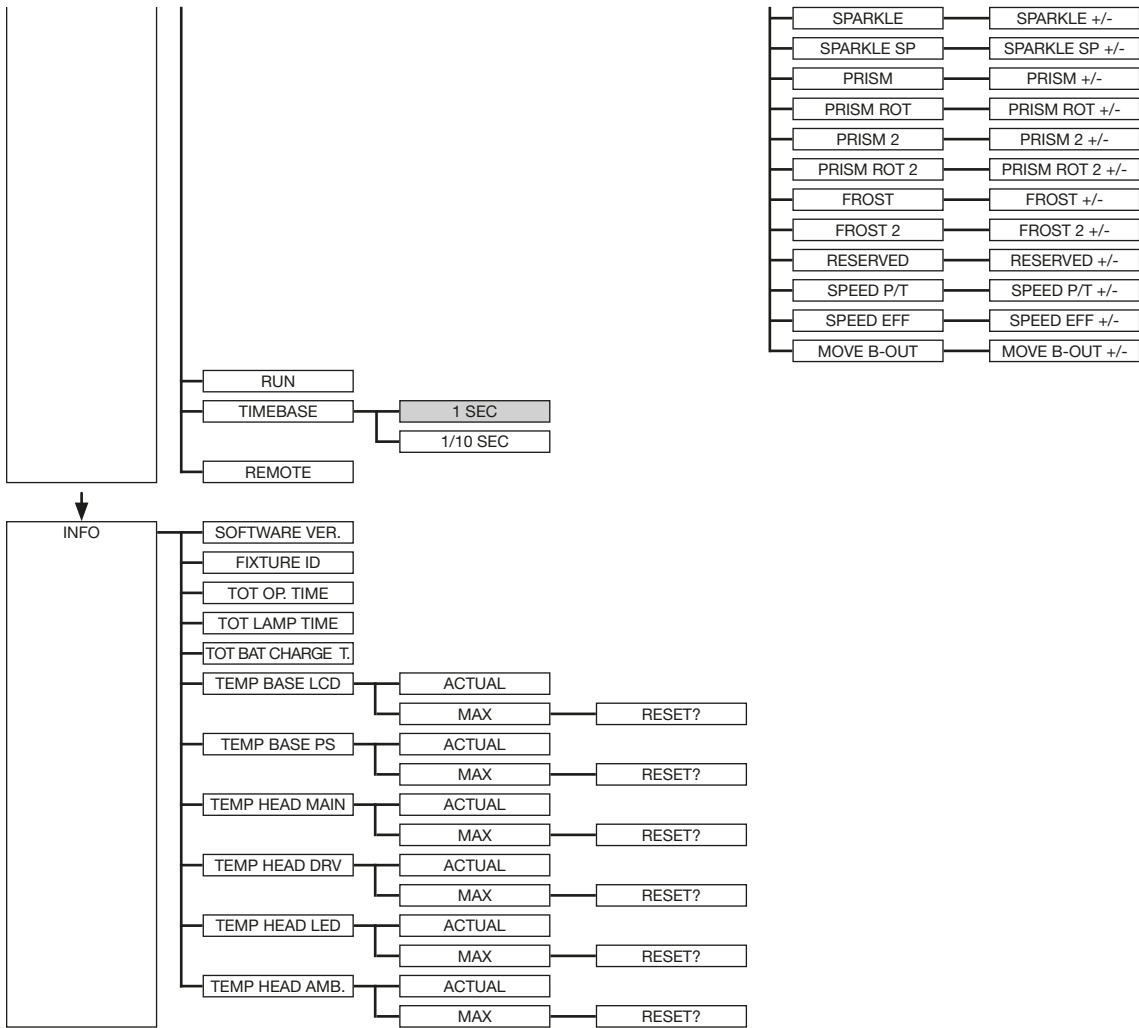

---

## 3.0 Ansteuerungsmöglichkeiten

### 3.1 DMX

#### 3.1.1 Übersicht DMX-Modi P18 MK2 Profile

Der P18 Profile MK2 verfügt über 2 unterschiedliche DMX-Modi. Der jeweilige Modus lässt sich im Menüpunkt PERSONALITY, DMX MODE einstellen. Der eingestellte Mode wird im Hauptmenü angezeigt.

	<b>Mode 1(M1)</b>	<b>Mode 2 (M2)</b>
Kanal 1	Pan	Pan
Kanal 2	Pan fein	Pan fein
Kanal 3	Tilt	Tilt
Kanal 4	Tilt fein	Tilt fein
Kanal 5	Steuerkanal	Steuerkanal
Kanal 6	Shutter	Shutter
Kanal 7	Dimmer	Dimmer
Kanal 8	Fokus	Dimmer fein
Kanal 9	Zoom	Fokus
Kanal 10	Autofokus Distanz	Fokus fein
Kanal 11	Autofokus Abgleich	Zoom
Kanal 12	Iris	Zoom fein
Kanal 13	Gobo 1	Autofokus Distanz
Kanal 14	Gobo 2	Autofokus Abgleich
Kanal 15	Gobo 2 Rotation	Iris
Kanal 16	Animationsrad	Iris fein
Kanal 17	Blende 1a	Gobo 1
Kanal 18	Blende 1b	Gobo 2
Kanal 19	Blende 2a	Gobo 2 Rotation
Kanal 20	Blende 2b	Gobo 2 Rotation fein
Kanal 21	Blende 3a	Animationsrad
Kanal 22	Blende 3b	Blende 1a
Kanal 23	Blende 4a	Blende 1a fein
Kanal 24	Blende 4b	Blende 1b
Kanal 25	Blende-Rotation	Blende 1b fein
Kanal 26	Farbrad	Blende 2a
Kanal 27	Cyan	Blende 2a fein
Kanal 28	Magenta	Blende 2b
Kanal 29	Yellow	Blende 2b fein
Kanal 30	CTO	Blende 3a
Kanal 31	Sparkle	Blende 3a fein
Kanal 32	Sparkle Geschwindigkeit	Blende 3b
Kanal 33	Prisma 1	Blende 3b fein
Kanal 34	Prisma 1 Rotation	Blende 4a
Kanal 35	Prisma 2	Blende 4a fein
Kanal 36	Prisma 2 Rotation	Blende 4b
Kanal 37	Frost 1	Blende 4b fein
Kanal 38	Frost 2	Blende-Rotation
Kanal 39	Effektmakro	Blende-Rotation fein

Kanal 40	Pan/Tilt-Geschwindigkeit	Farbrad
Kanal 41	Effekt-Geschwindigkeit	Cyan
Kanal 42	Blackout Move	Cyan fein
Kanal 43		Magenta
Kanal 44		Magenta fein
Kanal 45		Yellow
Kanal 46		Yellow fein
Kanal 47		CTO
Kanal 48		CTO fein
Kanal 49		Sparkle
Kanal 50		Sparkle Geschwindigkeit
Kanal 51		Prisma 1
Kanal 52		Prisma 1 Rotation
Kanal 53		Prisma 1 Rotation fein
Kanal 54		Prisma 2
Kanal 55		Prisma 2 Rotation
Kanal 56		Prisma 2 Rotation fein
Kanal 57		Frost 1
Kanal 58		Frost 2
Kanal 59		Effektmakro
Kanal 60		Pan/Tilt-Geschwindigkeit
Kanal 61		Effekt-Geschwindigkeit
Kanal 62		Blackout Move

# P18 MK2 PROFILE

## 3.1.2 DMX-Kanalfunktionen P18 Profile MK2 Profile









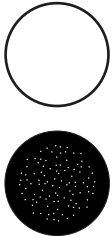



M1	M2	M3	Funktion	DMX
1	1		<b>Pan (X)</b> Bewegung 546,74°	000-255
2	2		<b>Pan (X)</b> fein (16 Bit)	000-255
3	3		<b>Tilt (Y)</b> Bewegung 281,16°	000-255
4	4		<b>Tilt (Y)</b> fein (16 Bit)	000-255
5	5		<p><b>Steuerkanal</b> Um gleichmäßiges Ausdimmen manuell über Fader für alle Lichtmischpulte zu ermöglichen stehen 5 verschiedene Einstellungen für die DMX-Glättung zur Verfügung. Sollte bei manchen DMX-Pulten das DMX-Signal abreißen oder zu wenige Pakete gesendet werden, kann mit diesem Kanal das Ansprechverhalten des Scheinwerfers angepasst werden. Die Einstellung für minimale DMX-Glättung sollte bei den meisten gängigen Pulten funktionieren. Die Werte für DMX-Glättung müssen Dauerhaft an den Scheinwerfer gesendet werden. Bei den anderen Werten wie z.B. Cooling Mode, Farbtemperatur usw. müssen die Werte für 2 Sekunden anliegen, dann wird das Gerät dauerhaft umgeschaltet. (Wie bei der Umstellung im Menü PERSONALITY)</p> <p><b>Einstellung für minimale DMX-Glättung</b> (Eine gedimmte Shuttersequenz ist möglich) Dimmer Fade out über Fader (schnell - langsam) nicht belegt</p> <p><b>Einstellung für minimale/mittlere DMX-Glättung</b> Dimmer Fade out über Fader (schnell - langsam) nicht belegt</p> <p><b>Einstellung für mittlere DMX-Glättung</b> Dimmer Fade out über Fader (schnell - langsam) nicht belegt</p> <p><b>Einstellung für mittlere/maximale DMX-Glättung</b> Dimmer Fade out über Fader (schnell - langsam)</p> <p><b>BACKLIGHT MODE - Display-Hintergrundbeleuchtung</b> AUTO - der Scheinwerfer steuert die Hintergrundbeleuchtung automatisch ON - die Hintergrundbeleuchtung ist immer an OFF - die Hintergrundbeleuchtung ist immer aus, bis eine Taste gedrückt wird</p> <p><b>DISPLAY ORIENTATION - Displayausrichtung</b> STANDARD - das display ist zu lesen wenn der Scheinwerfer steht FLIP - die Displayausrichtung ist um 180° gedreht, hängend lesbar nicht belegt</p> <p><b>MAIN SCREEN MODE - Ansicht Hauptbildschirm</b> STANDARD - der Hauptbildschirm zeigt die DMX-Adresse, den DMX-Mode und bei aktiviertem Wireless die Feldstärke an. USER FIXTURE ID - der Hauptbildschirm zeigt die frei definierbare Fixture-ID / Scheinwerfernummer an nicht belegt</p> <p><b>USER FIXTURE ID SET - Scheinwerfernummer setzen</b> SET - hiermit kann die USER ID eingestellt werden. der Scheinwerfer übernimmt den 16Bit Wert von Pan für die USER ID nicht belegt</p>	<p>000-007 008-031</p> <p>032-039 040-063</p> <p>064-071 072-095</p> <p>096-103</p> <p>104-104 105-105 106-106</p> <p>107-107 108-108 109-109</p> <p>110-110 111-111 112-112</p> <p>113-113 114-127</p>

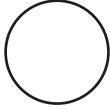

	<p><b>Einstellung für maximale DMX-Glättung</b> Dimmer Fade out über Fader (schnell - langsam)</p>	128-135
	<p><b>DIMMER CURVE - Einstellung der Dimmerkurve</b> LINEAR - lineare Dimmerkurve SQUARE - exponentielle Dimmerkurve SQUARE INVERS - exponentiell inverse Dimmerkurve nicht belegt</p>	136-136 137-137 138-138 139-139
	<p><b>RGB/CMY CURVE - Einstellung der RGB/CMY-Kurve</b> LINEAR - lineare RGB/CMY-Kurve SQUARE INVERS - exponentiell inverse RGB/CMY-Kurve nicht belegt</p>	140-140 141-141 142-142
	<p><b>FROST CURVE - Einstellung der Frostkurve</b> LINEAR - lineare Frostkurve SQUARE INVERS - exponentiell inverse Frostkurve nicht belegt</p>	143-143 144-144 145-145
	<p><b>PAN/TILT SPEED - Pan/Tilt-Geschwindigkeit</b> WHISPER SILENT MEDIUM FAST</p>	146-146 147-147 148-148 149-149
	<p><b>EFFECT SPEED - Effekt-Geschwindigkeit</b> WHISPER SILENT MEDIUM FAST</p>	150-150 151-151 152-152 153-153
	<p><b>LED FADE OUT MODE - Art der Ausdimmung</b> STANDARD SOFT nicht belegt</p>	154-154 155-155 156-159
	<p><b>COOLING MODE - Einstellung der Lüfterlautstärke und der Helligkeit</b> Die Umschaltung erfolgt mit Dimmer/Shutter zu (DMX 000) dann nach 2 Sekunden außer die Schalter "SAFE MODE SWITCH" im PERSONALITY-Menü sthet auf OFF, dann kann die Umschaltung direkt erfolgen ohne dass Dimmer und Shutter zu sein müssen. THEATRE WHISPER THEATRE SILENT STANDARD BOOST LONGLIFE nicht belegt</p>	160-160 161-161 162-162 163-163 164-164 165-207
	<p><b>CAMERA MODE - Einstellung der LED-Wiederhofrequenz</b> 50Hz 60Hz FLEX - 600Hz High FLEX - 3kHz nicht belegt</p>	208-215 216-223 224-227 228-231 232-239
	<p><b>RESET - ein Grundreset des Scheinwerfers wird durchgeführt</b> Reset (nach 2 Sekunden) nicht belegt</p>	240-247 248-255

# P 18 MK2 PROFILE

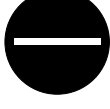
6	6	<b>Shutter</b> Shutter zu Shutter auf Shutter pulsierend öffnen >20Hz (schnell - langsam) Shutter auf Fade-Effekt mit Dimmer (langsam - schnell) Shutter auf Shutter zu Shutter pulsierend öffnen <20Hz (schnell - langsam) Shutter auf Shutter pulsierend schließen (schnell - langsam) Shutter zu Shutter fade, 0% (schnell - langsam) Shutter auf Shutter fade, 100% (schnell - langsam) Shutter zu Shutter Zufall 100% (schnell - langsam) Shutter auf Shutter Zufall 0% (schnell - langsam) Shutter zu Shutter Zufall fade 0% (schnell - langsam) Shutter auf Shutter Zufall fade 100% (schnell - langsam) Shutter auf	000-015 016-095 096-110 111-111 112-125 126-126 127-126 128-142 143-143 144-158 159-159 160-174 175-175 176-190 191-191 192-206 207-207 208-222 223-223 224-238 239-239 240-254 255-255
7	7	<b>Dimmer 0 - 100%</b>	000-255
	8	<b>Dimmer fein (16Bit)</b>	000-255
8	9	<b>Fokus 0-100%</b>	000-255
	10	<b>Fokus fein (16 Bit)</b>	000-255
9	11	<b>Zoom 0 -100% (nah 7° - weit 56°)</b>	000-255
	12	<b>Zoom fein (16 Bit)</b>	000-255
10	13	<b>Autofokus Distanz</b> Autofokus aus Autofokus 0 m - 100 m	000-001 002-255
11	14	<b>Autofokus Feinabgleich</b> Autofokus Feinabgleich - 128 Mittelstellung	000-255
12	15	<b>Iris 0-100% (offen -&gt; zu)</b>	000-255
	16	<b>Iris fein (16Bit)</b>	000-255
		<b>Goborad 1</b> Gobo 0  Gobo 1	 000-007  008-015

13	17	Gobo 2		016-023
		Gobo 3		024-031
		Gobo 4		032-039
		Gobo 5		040-047
		Gobo 6		048-055
		Gobo 7		056-063
		Gobo 8		064-191
				Goboraddurchlauf rechts (schnell - langsam) Goboraddurchlauf links (langsam - schnell)
14	18	<b>Goborad 2 - rotierende Gobos</b>		
		Gobo 0		000-007
		Gobo 1		008-015
		Gobo 2		016-023
		Gobo 3		024-031
		Gobo 4		032-039
		Gobo 5		040-047
Gobo 6		048-255		

# P 18 MK2 PROFILE

15	19	<b>Gobopositionierung / -rotation 2</b> Gobopositionierung 0°-540° Goborotation rechts (schnell - langsam) Goborotation Stop Goborotation links (langsam - schnell)	000-191 192-222 223-224 225-255
	20	<b>Gobopositionierung / -rotation 2 fein (16 Bit)</b>	000-255
16	21	<b>Animationsrad</b> Offen Wassereffekt gefadet Mittelposition Wassereffekt gefadet Stop Wassereffekt gefadet (langsam -> schnell) Wassereffekt geschaltet Mittelposition Wassereffekt geschaltet Stop Wassereffekt geschaltet (langsam -> schnell) Feuereffekt gefadet Mittelposition Feuereffekt gefadet Stop Feuereffekt gefadet (langsam -> schnell) Feuereffekt geschaltet Mittelposition Feuereffekt geschaltet Stop Feuereffekt geschaltet (langsam -> schnell)	000-000 001-001 002-002 003-063 064-064 065-065 066-127 128-128 129-129 130-191 192-192 193-193 194-255
17	22	<b>Blende 1a 0-100%</b>	000-255
	23	<b>Blende 1a fein (16 Bit)</b>	000-255
18	24	<b>Blende 1b 0-100%</b>	000-255
	25	<b>Blende 1b fein (16 Bit)</b>	000-255
19	26	<b>Blende 2a 0-100%</b>	000-255
	27	<b>Blende 2a fein (16 Bit)</b>	000-255
20	28	<b>Blende 2b 0-100%</b>	000-255
	29	<b>Blende 2b fein (16 Bit)</b>	000-255
21	30	<b>Blende 3a 0-100%</b>	000-255
	31	<b>Blende 3a fein (16 Bit)</b>	000-255
22	32	<b>Blende 3b 0-100%</b>	000-255
	33	<b>Blende 3b fein (16 Bit)</b>	000-255
23	34	<b>Blende 4a 0-100%</b>	000-255
	35	<b>Blende 4a fein (16 Bit)</b>	000-255
24	36	<b>Blende 4b 0-100%</b>	000-255
	37	<b>Blende 4b fein (16 Bit)</b>	000-255

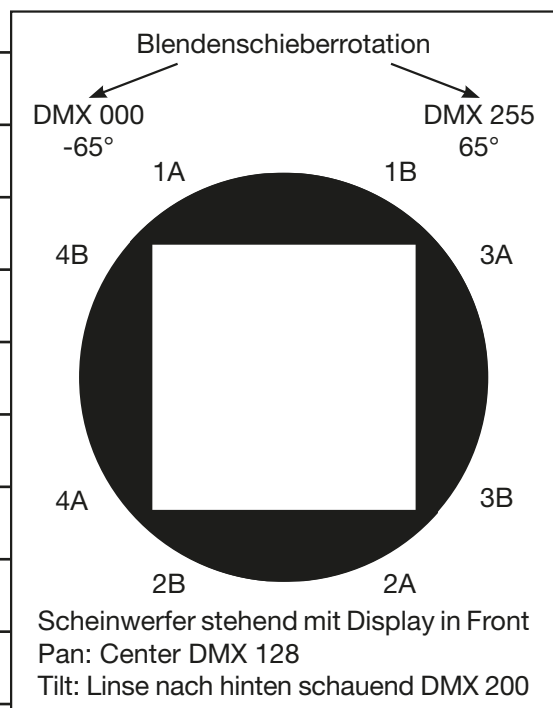

25	38	<b>Blendenschieber-Rotation</b> -45° / +45°	000-255
	39	<b>Blendenschieber-Rotation fein</b> (16 Bit)	000-255
26	40	<b>Farbrad</b> Weiss 000-001 Weiss / Rot 002-003 Rot 004-005 Rot / Gelb 006-007 Gelb 008-009 Gelb / Magenta 010-011 Magenta 012-013 Magenta / Grün 014-015 Grün 016-017 Grün / Orange 018-019 Orange 020-021 Orange / Dunkelblau 022-023 Dunkelblau 024-025 Dunkelblau / HCRI 026-027 HCRI 028-029 HCRI / Weiss 030-031 Farben linear: Weiss - Rot - Gelb - Magenta - Grün - Orange - Dunkelblau - HCRI - Weiss 064-191 Farbraddurchlauf rechts (schnell - langsam) 192-223 Farbraddurchlauf links (langsam - schnell) 224-255	
27	41	<b>Cyan</b> (8 Bit) 0-100%	000-255
	42	<b>Cyan fein</b> (16 Bit)	000-255
28	43	<b>Magenta</b> (8 Bit) 0-100%	000-255
	44	<b>Magenta fein</b> (16 Bit)	000-255
29	45	<b>Yellow (Gelb)</b> (8 Bit) 0-100%	000-255
	46	<b>Yellow (Gelb) fein</b> (16 Bit)	000-255
30	47	<b>CTO</b> (8 Bit) 0-100%	000-255
	48	<b>CTO fein</b> (16 Bit)	000-255
31	49	<b>Sparkle - Glittereffekt</b> Sparkle Effekt inaktiv 000-000 Sparkle Effekt Intensität (minimum - maximum) 001-255	
32	50	<b>Sparkle Geschwindigkeit</b> Sparkle Effekt gefadet (langsam -> schnell) 000-031 Sparkle Effekt geschaltet (langsam -> schnell) 032-063 Wiederholung der Fade- und Schaltblöcke 064-255	
33	51	<b>Prisma 1</b> Offen 000-007 Prisma 1 (5fach linear) 008-255	

# P 18 MK 2 PROFILE

34	52	<b>Prisma 1 Positionierung / Rotation</b> Prisma Positionierung (0°-540°) Prisma Rotation rechts (schnell -> langsam) Prisma Rotation stop Prisma Rotation links (langsam -> schnell)	000-191 192-222 223-224 225-255
	53	<b>Prisma 1 Positionierung / Rotation fein (16 Bit)</b>	000-255
35	54	<b>Prisma 2</b> Offen Prisma 2 (3fach kreisförmig)	000-007 008-255
36	55	<b>Prisma 2 Positionierung / Rotation</b> Prisma Positionierung (0°-540°) Prisma Rotation rechts (schnell -> langsam) Prisma Rotation stop Prisma Rotation links (langsam -> schnell)	000-191 192-222 223-224 225-255
	56	<b>Prisma 2 Positionierung / Rotation fein (16 Bit)</b>	000-255
37	57	<b>Frost 1</b> Frost 0-100%	000-255
38	58	<b>Frost 2</b> Frost 0-100%	000-255
39	59	<b>Effektmakro</b> Makro inaktiv Makro 001 - Makro 255	000-000 001-255
40	60	<b>Pan/Tilt Geschwindigkeit</b> Bewegung in Echtzeit Bewegung zeitverzögert (schnell - langsam)	000-003 004-255
41	61	<b>Effektgeschwindigkeit</b> Effekte in Echtzeit Effekte zeitverzögert (schnell - langsam)	000-003 004-255
42	62	<b>Blackout Move</b> Nicht belegt Blackout bei Pan/Tilt Blackout bei Gobo, Farbe, Prisma, CMY, Iris, Frost Blackout bei Gobo, Farbe, Prisma, CMY, Iris, Frost, Zoom, Fokus Blackout bei Gobo, Farbe, Prisma, CMY, Iris, Frost, Pan/Tilt Blackout bei Gobo, Farbe, Prisma, CMY, Iris, Frost, Zoom, Fokus, Pan/Tilt	000-095 096-127 128-159 160-191 192-223 224-255

### 3.1.3 Steuerkanal

Über den Steuerkanal können verschieden Funktionen des Scheinwerfers permanent umgeschaltet werden. Folgende Funktionen können über den Steuerkanal umgeschaltet werden.

Ansprechverhalten des Scheinwerfers beim Ausdimmen über Fader

BACKLIGHT MODE - Display Hintergrundbeleuchtung

DISPLAY ORIENTATION - Displayausrichtung

MAIN SCREEN MODE - Ansicht Hauptbildschirm

USER FIXTURE ID SET - Scheinwerfernummer setzen

DIMMER CURVE - Einstellung der Dimmerkurve

RGB/CMY CURVE - Einstellung der RGB/CMY-Kurve

FROST CURVE - Einstellung der Frostkurve

PAN/TILT SPEED - Pan/Tilt-Geschwindigkeit

EFFECT SPEED - Effekt-Geschwindigkeit

LED FADE OUT MODE - Art der Ausdimmung

COOLING MODE - Einstellung der Lüfterlautstärke und der Helligkeit

CAMERA MODE - Einstellung der LED-Wiederholfrequenz

RESET - Ein Grundreset des Scheinwerfers wird durchgeführt

Die Details hierzu siehe DMX-Kanalfunktionen für den P18 Profile MK2 auf der Seite 08.

### 3.1.4 Sparkle Effekt, Sparklegeschwindigkeit

Über diesen Kanal können in Verbindung mit dem Fokus Animationseffekte erzeugt werden. Je nach Intensität wird die Abbildung mehr oder weniger zum pulsieren angeregt. Dieser Effekt kann gefadet oder geschaltet werden.

### 3.1.5 Autofokus

Zum Aktivieren der Autofokusfunktion den Kanal Autofokus-Distanz auf etwa 50 % stellen. Danach für die Feinjustage des Systems am besten Goborad 2 verwenden und entsprechend den Fokus auf 125 (32000) einstellen: Anschließend über Autofokus-Distanz die Entfernung des Scheinwerfers durch scharf stellen des Scheinwerfers einstellen. Als Richtwert kann der DMX-Wert geteilt durch 10 für die Entfernung (DMX 100 / 10 Entfernung = 10m) angenommen werden. Jetzt kann der Scheinwerfer über den Zoom mit Autofokus betrieben werden. Anhand der folgenden Tabelle können nun die Fokuswerte für die einzelnen Effekte vorgewählt werden und über Zoom mit Autofokus gezoomt werden.

	Animation	Gobo1	Gobo2	Open	Blenden	Iris
Fokus 8Bit	55	95	145	185	195	215
Fokus 16Bit	14080	24320	37120	47360	49920	55040

### 3.2 Artnet

Der Scheinwerfer kann über Artnet - ArtNET 4 angesteuert werden. Hierzu über den Menüpunkt DMX / NET ADDR -> ARTNET ADDRESS die Artnetadresse einstellen und zusätzlich über den Menüpunkt PERSONALITY -> DMX INPUT CONFIG -> NETWORK -> MODE -> ARTNET auswählen. Zusätzlich noch die IP-Adresse des Scheinwerfers über PERSONALITY -> DMX INPUT CONFIG -> NETWORK -> IP ADDRESS definieren.

### 3.3 Streaming ACN

Der Scheinwerfer kann über sACN - Streaming ACN angesteuert werden. Hierzu über den Menüpunkt DMX / NET ADDR -> SACN ADDRESS die sACN-Adresse einstellen und zusätzlich über den Menüpunkt PERSONALITY -> DMX INPUT CONFIG -> NETWORK -> MODE -> SACN auswählen. Zusätzlich noch die IP-Adresse des Scheinwerfers über PERSONALITY -> DMX INPUT CONFIG -> NETWORK -> IP ADDRESS definieren.

## 3.4 Wireless-DMX

Der P18 ist mit einem Lumen-Radio CRMX-Empfänger für Wireless DMX ausgestattet. Der Empfänger kann sowohl DMX als auch RDM verarbeiten. Sollte eine Kabel und Wirelessverbindung am P18 anliegen hat die Kabelverbindung Vorrang! Das empfangene Signal kann über den DMX-Anschluß ausgegeben werden. Hierzu im Menü PERSONALITY die Einstellung DMX OUTPUT CONFIG auf ON stellen, nach Bestätigung mit ENTER gibt der Scheinwerfer das komplette über Wireless-DMX empfangene Universum aus.

## 3.5 RDM

Der P18 kann über RDM (Remote Device Management) gemäß ESTA American National Standard E1.20-2006 kommunizieren. RDM ist ein bidirektionales Kommunikationsprotokoll für den Einsatz in DMX512-Steuerungssystemen. Es ist der offene Standard für die Konfiguration und Statusüberwachung von DMX-512-Geräten. Das RDM-Protokoll ermöglicht das Einfügen von Datenpaketen in einen DMX-512-Datenstrom, ohne dass bestehende Nicht-RDM-Geräte beeinträchtigt werden. Es ermöglicht einer Konsole oder einem dedizierten RDM-Controller, Befehle an bestimmte Geräte zu senden und Nachrichten zu empfangen. Der P18 kann RDM über Artnet 4 und DMX senden und empfangen. Ebenfalls ist der Scheinwerfer dafür ausgelegt RDM über sACN zu senden und über Artnet zu empfangen. Die RDM-Funktionalität ist abhängig vom eingesetzten Lichtsteuerpult, hierzu muss ebenfalls die Bedienungsanleitung des jeweiligen Pultherstellers beachtet werden.

### 3.5.1 RDM-UID

Jeder P18 hat eine werksseitig festgelegte RDM-UID (eindeutige Identifikationsnummer), die ihn in RDM-Systemen adressierbar und identifizierbar macht.

### 3.5.2 RDM-PIDs

Der P18 unterstützt die gemäß ESTA erforderlichen RDM-PIDs (Parameter-IDs) sowie hersteller-spezifische PIDs.

### 3.5.3 Standard RDM-Parameter-IDs

RDM-Parameter-ID	GET Befehl	SET Befehl	DISCOVERY	Anmerkungen
RDM-Identifikation				
DISC_UNIQUE_BRANCH			✓	dient der Scheinwerferidentifikation
DISC_MUTE			✓	dient der Scheinwerferidentifikation
DISC_UN_MUTE			✓	dient der Scheinwerferidentifikation
RDM-Statusermittlung				
QUEUED_MESSAGE	✓			
STATUS_MESSAGES	✓			
STATUS_ID_DESCRIPTION	✓			
CLEAR_STATUS_ID		✓		
RDM-Information				
SUPPORTED_PARAMETERS	✓			
RDM-Konfiguration				
DEVICE_MODEL_DESCRIPTION	✓			
MANUFACTURER_LABEL	✓			
FACTORY_DEFAULTS		✓		
SOFTWARE_VERSION_LABEL	✓			
DMX_PERSONALITY		✓		
DMX_PERSONALITY_DESCRIPTION	✓			
DMX_START_ADDRESS		✓		



SENSOR_DEFINITION	✓			
DEVICE_HOURS	✓			
LAMP_HOURS	✓			
IDENTIFY_DEVICE		✓		
RESET_DEVICE		✓		
PERFORM_SELFTEST		✓		
SELFTEST_DESCRIPTION	✓			

### 3.5.4 Herstellerspezifische RDM-Parameter-IDs

RDM-Parameter-ID	GET Befehl	SET Befehl	DISCO-VERY	Anmerkungen
<b>RDM-Konfiguration</b>				
Battery Charge Hours	✓			
Error Number	✓			
Error	✓			
Select Next Error		✓		
Remove Error		✓		
Remove New Error Flag		✓		
User Defaults		✓		
User Fixture ID		✓		
Fixture Lock On/Off	✓	✓		
Dimmer Curve	✓	✓		
RGB Curve	✓	✓		
Frost Curve	✓	✓		
Camera Mode	✓	✓		
Cooling Mode	✓	✓		
Pan Tilt Speed	✓	✓		
Effect Speed	✓	✓		
Backlight Mode	✓	✓		
Disp Orientation	✓	✓		
Main Screen Mode	✓	✓		
Safe Mode Switch	✓	✓		
LED Fade Out Mode	✓	✓		
Blade Mode	✓	✓		

### 3.5.5 RDM-Sensoren-IDs

RDM-Sensor-ID	GET Befehl	SET Befehl	DISCO-VERY	Anmerkungen
<b>RDM-Sensoren</b>				
Temp Sens Base LCD	✓	✓		
Temp Sens Base PS	✓	✓		
Temp Sens Head PCB	✓	✓		
Temp Sens Head Drv	✓	✓		
Temp Sens Head LED	✓	✓		
Temp Sens Head Air	✓	✓		

English

## 4.0 P18 Profile MK2 models

The P18 Profile MK2 is available in 3 models. The models differ in the light module and partly in the color filters and in the CTC filters. The differences can be found in the DMX channel functions.

- P18 Profile MK2 HP (High Power)
- P18 Profile MK2 HC (High CRI)
- P18 Profile MK2 WW (Warm white)

## 5.0 Menu navigation

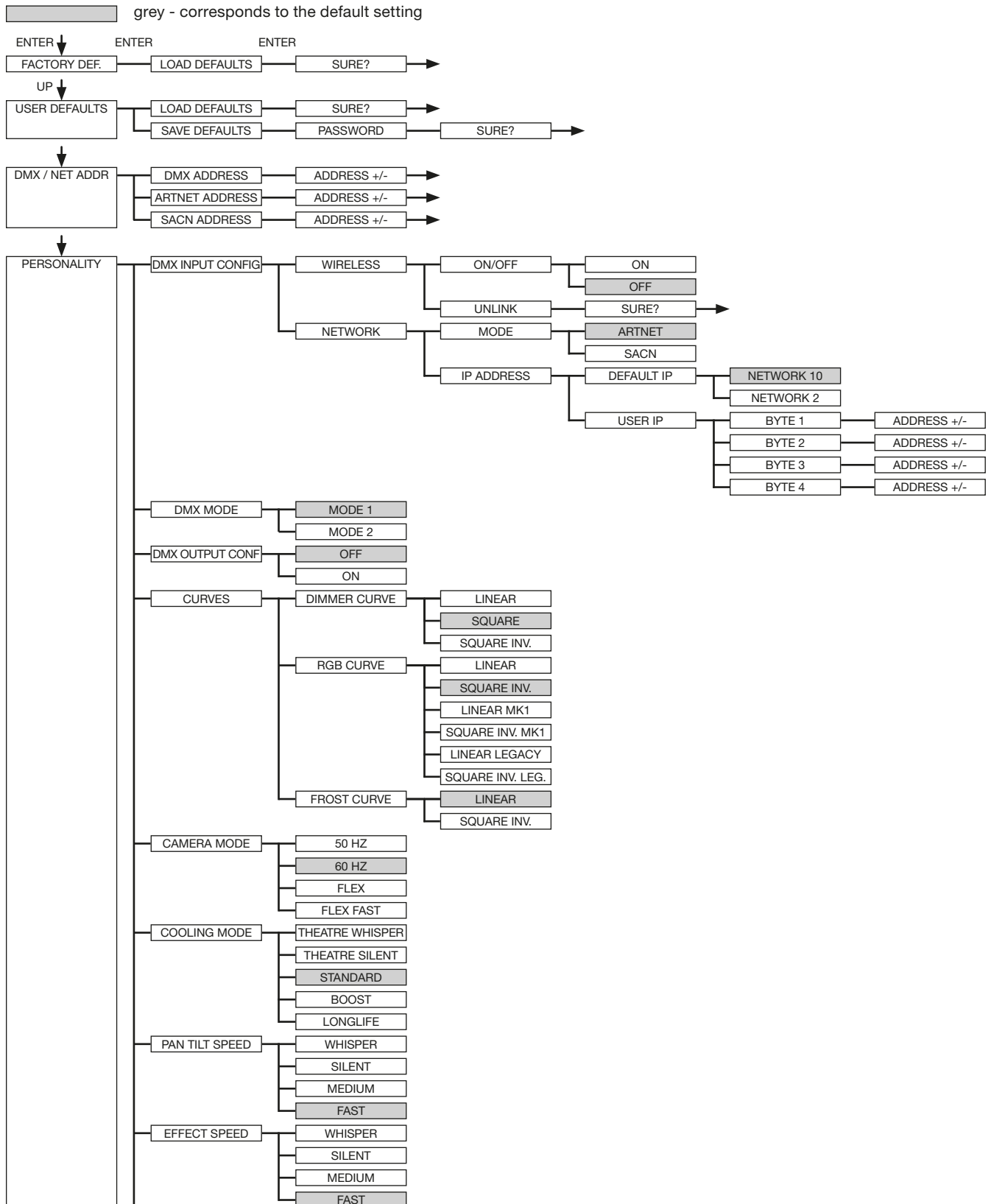

# P 18 MK2 PROFILE

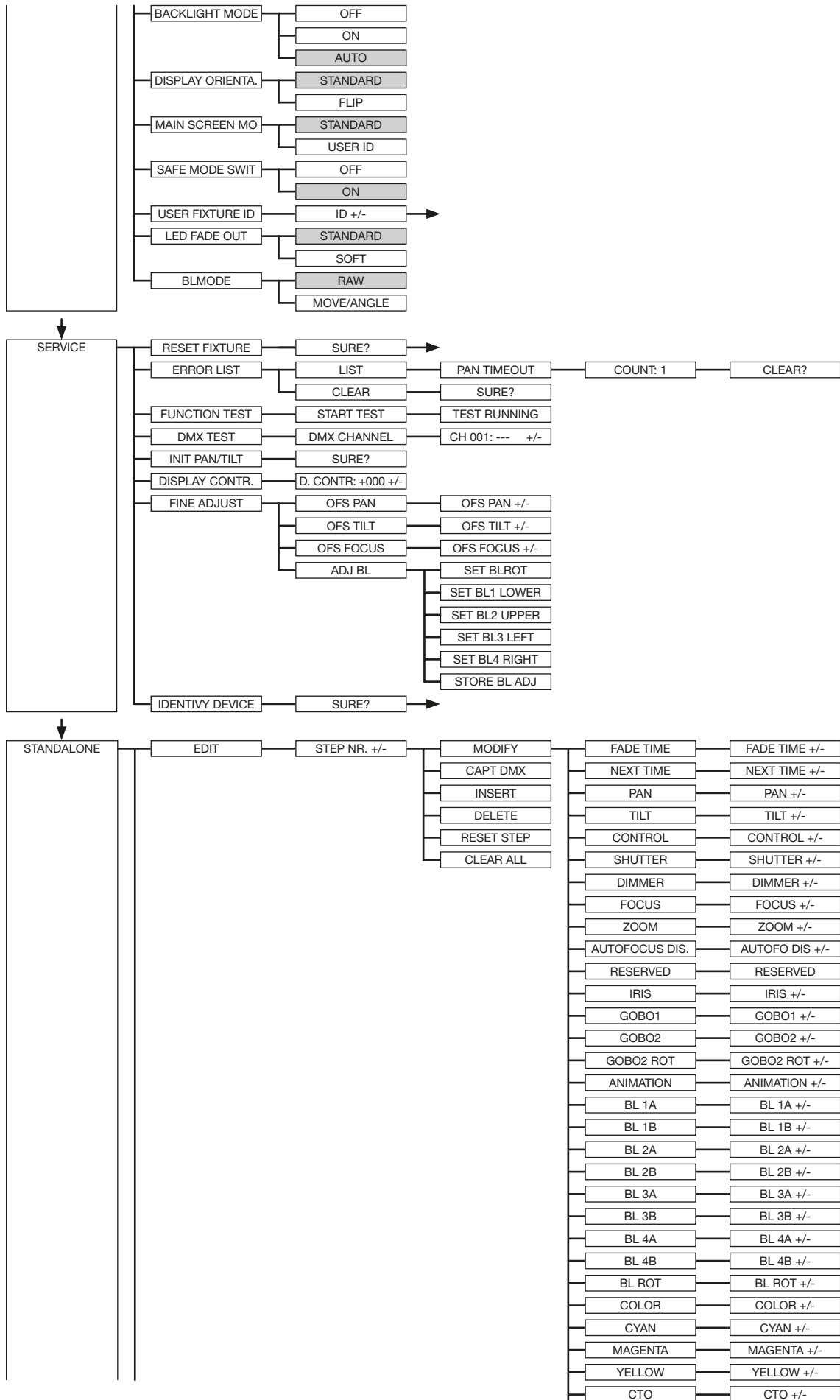

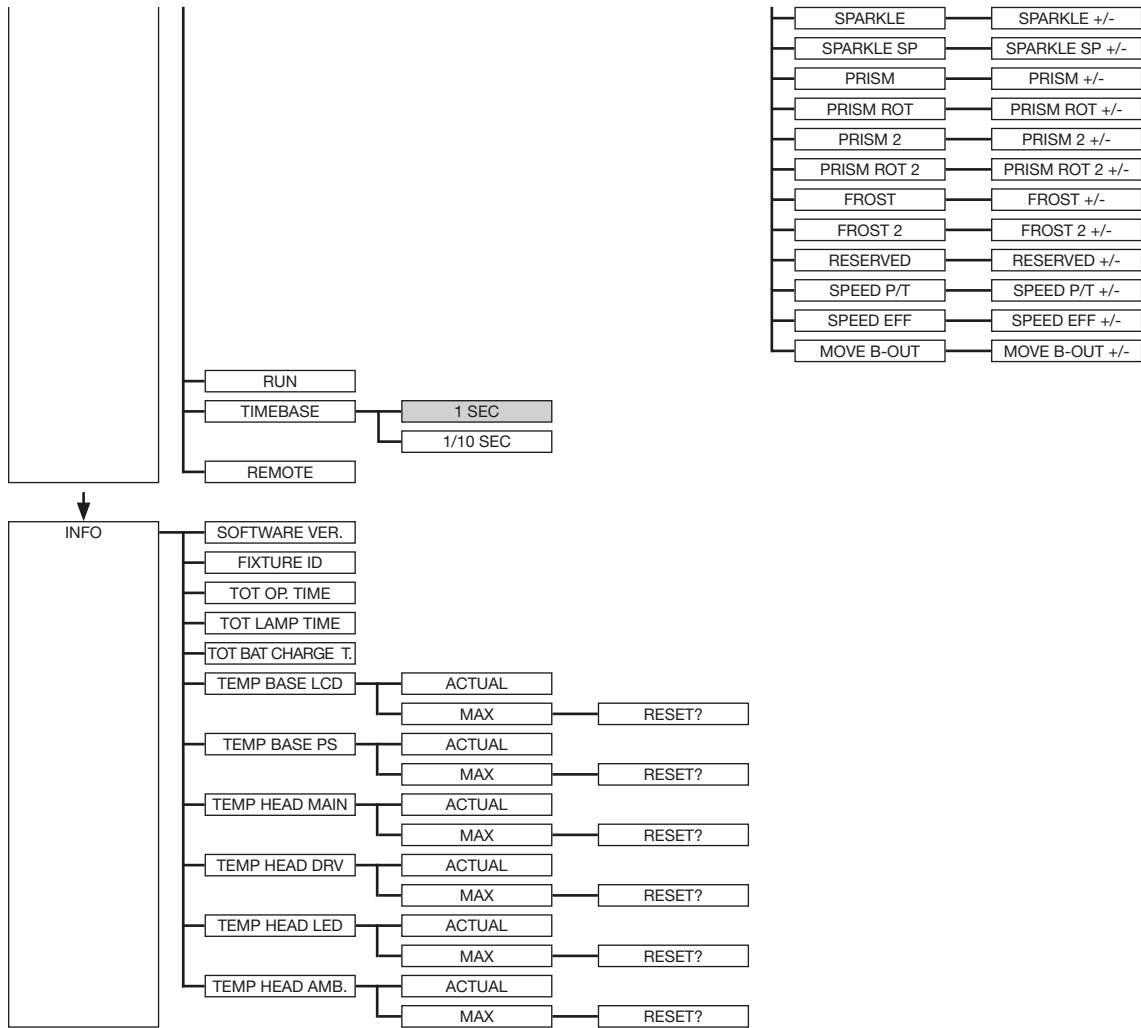

# P18 MK2 PROFILE

---

## 6.0 Control options

### 6.1 DMX

#### 6.1.1 Operating modes P18 MK2 Profile

The P18 MK2 Profile has 2 different DMX modes. The respective mode can be set in the PERSONALITY, DMX MODE menu item. The set mode is displayed in the main menu.

	<b>Mode 1(M1)</b>	<b>Mode 2 (M2)</b>
Channel 1	Pan	Pan
Channel 2	Pan fine	Pan fine
Channel 3	Tilt	Tilt
Channel 4	Tilt fine	Tilt fine
Channel 5	Control channel	Control channel
Channel 6	Shutter	Shutter
Channel 7	Dimmer	Dimmer
Channel 8	Focus	Fine dimmer
Channel 9	Zoom	Focus
Channel 10	Autofocus distance	Fine focus
Channel 11	Autofocus balancing	Zoom
Channel 12	Iris	Fine zoom
Channel 13	Gobo 1	Autofocus distance
Channel 14	Gobo 2	Autofocus balancing
Channel 15	Gobo 2 rotation	Iris
Channel 16	Animation wheel	Fine iris
Channel 17	Aperture 1a	Gobo 1
Channel 18	Aperture 1b	Gobo 2
Channel 19	Aperture 2a	Gobo 2 rotation
Channel 20	Aperture 2b	Gobo 2 fine rotation
Channel 21	Aperture 3a	Animation wheel
Channel 22	Aperture 3b	Aperture 1a
Channel 23	Aperture 4a	Aperture 1a fine
Channel 24	Aperture 4b	Aperture 1b
Channel 25	Aperture rotation	Aperture 1b fine
Channel 26	Colour wheel	Aperture 2a
Channel 27	Cyan	Aperture 2a fine
Channel 28	Magenta	Aperture 2b
Channel 29	Yellow	Aperture 2b fine
Channel 30	CTO	Aperture 3a
Channel 31	Sparkle	Aperture 3a fine
Channel 32	Sparkle speed	Aperture 3b
Channel 33	Prism 1	Aperture 3b fine
Channel 34	Prism 1 rotation	Aperture 4a
Channel 35	Prism 2	Aperture 4a fine
Channel 36	Prism 2 rotation	Aperture 4b
Channel 37	Frost 1	Aperture 4b fine
Channel 38	Frost 2	Aperture rotation
Channel 39	Effects macro	Fine aperture rotation
Channel 40	Pan/tilt speed	Colour wheel
Channel 41	Effect speed	Cyan

Channel 42	Blackout Move	Fine cyan
Channel 43		Magenta
Channel 44		Fine magenta
Channel 45		Yellow
Channel 46		Fine yellow
Channel 47		CTO
Channel 48		CTO fine
Channel 49		Sparkle
Channel 50		Sparkle speed
Channel 51		Prism 1
Channel 52		Prism 1 rotation
Channel 53		Prism 1 fine rotation
Channel 54		Prism 2
Channel 55		Prism 2 rotation
Channel 56		Prism 2 fine rotation
Channel 57		Frost 1
Channel 58		Frost 2
Channel 59		Effects macro
Channel 60		Pan/tilt speed
Channel 61		Effect speed
Channel 62		Blackout Move

# P18 MK2 PROFILE

## 6.1.2 DMX channel functions P18 Profile MK2 Profile









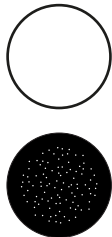



M1	M2	M3	Function	DMX
1	1		<b>Pan (X)</b> movement 546,74°	000-255
2	2		<b>Pan (X)</b> fine (16 Bit)	000-255
3	3		<b>Tilt (Y)</b> movement 281.16°	000-255
4	4		<b>Tilt (Y)</b> fine (16 Bit)	000-255
5	5		<p><b>Control channel</b>            To enable uniform dimming manually via faders for all light mixing consoles, 5 different settings for the DMX smoothing are available. If the DMX signal is interrupted or too few packets are sent on some DMX consoles, the response of the Sparx 18/30 can be adjusted with this channel. The Minimum DMX Smoothing setting should work on most popular consoles. The values for DMX smoothing must be permanent. For the other values, such as cooling mode, color temperature, zoom modes, camera mode, reset, the values must be applied for 2 seconds, then the device will be permanently switched (Same setting as in the PERSONALITY menu).</p> <p><b>Setting for minimal DMX smoothing</b>            (A dimmed shutter sequence is possible)            Dimmer fade out via fader (fast - slow)            not used</p> <p><b>Setting for minimum / medium DMX smoothing</b>            Dimmer fade out via fader (fast - slow)            not used</p> <p><b>Setting for medium DMX smoothing</b>            Dimmer fade out via fader (fast - slow)            not used</p> <p><b>Setting for medium / maximum DMX smoothing</b>            Dimmer fade out via fader (fast - slow)</p> <p><b>BACKLIGHT MODE - Display backlight configuration</b>            AUTO - the fixture controls the backlight automatically            ON - the backlight is always on            OFF - the backlight is always off until a key is pressed</p> <p><b>DISPLAY ORIENTATION - display flip or not</b>            STANDARD - the display can be read when the headlamp is on a surface            FLIP - the display orientation is rotated by 180 °, hanging readable            not used</p> <p><b>MAIN SCREEN MODE - view of the main screen</b>            STANDARD - the main screen displays the DMX address, the DMX mode, and when wireless is enabled, the field strength.            USER FIXTURE ID - the main screen displays the user definable fixture ID / head-light number            not used</p> <p><b>USER FIXTURE ID SET - Scheinwerfernummer setzen</b>            SET - the USER ID can be set. The headlamp takes the 16-bit value of Pan for the USER ID            not used</p>	<p>000-007 008-031</p> <p>032-039 040-063</p> <p>064-071 072-095</p> <p>096-103</p> <p>104-104 105-105 106-106</p> <p>107-107 108-108 109-109</p> <p>110-110 111-111 112-112</p> <p>113-113 114-127</p>

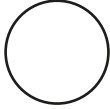

	<p><b>Setting for maximum DMX smoothing</b> Dimmer fade out via fader (fast - slow)</p>	128-135
	<p><b>DIMMER CURVE - selection of dimmer curve</b> LINEAR - linear dimmer curve SQUARE - exponential dimmer curve SQUARE INVERSE - exponential inverse dimmer curve not used</p>	136-136 137-137 138-138 139-139
	<p><b>RGB/CMY CURVE - selection of RGB/CMY curve</b> LINEAR - linear RGB/CMY curve SQUARE INVERSE - Exponential inverse RGB/CMY curve not used</p>	140-140 141-141 142-142
	<p><b>FROST CURVE - selection of frost curve</b> LINEAR - linear frost curve SQUARE INVERSE - Exponential inverse frost curve not used</p>	143-143 144-144 145-145
	<p><b>PAN/TILT SPEED - selection of PAN/TILT speed</b> WHISPER SILENT MEDIUM FAST</p>	146-146 147-147 148-148 149-149
	<p><b>EFFECT SPEED - selection of effect speed</b> WHISPER SILENT MEDIUM FAST</p>	150-150 151-151 152-152 153-153
	<p><b>LED FADE OUT MODE - selection of dimming out</b> STANDARD SOFT not used</p>	154-154 155-155 156-159
	<p><b>COOLING MODE - Adjust the fan volume and brightness</b> This takes place with dimmer / shutter set to closed (DMX 000) then after 2 seconds the fixture will switch this option, except the switch "SAFE MODE SWITCH" in the PERSONALITY menu is set to OFF, then the changeover can take place directly without dimmer and shutter having to be closed. THEATRE WHISPER THEATRE SILENT STANDARD BOOST LONGLIFE not used</p>	160-160 161-161 162-162 163-163 164-164 165-207
	<p><b>CAMERA MODE - Setting the LED refresh rate</b> 50Hz 60Hz FLEX - 600Hz High FLEX - 3kHz not used</p>	208-215 216-223 224-227 228-231 232-239
	<p><b>RESET - a basic reset of the fixture is carried out</b> Reset nicht belegt</p>	240-247 248-255

# P 18 MK2 PROFILE

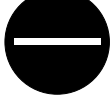
6	6	<b>Shutter</b> Shutter closed Shutter open Open pulsing shutter >20Hz (rapid - slow) Shutter open Fade effect with dimmer (slow - rapid) Shutter open Shutter closed Open pulsing shutter <20Hz (rapid - slow) Shutter open Close pulsing shutter >20Hz (rapid - slow) Shutter closed Shutter fade, 0% (rapid - slow) Shutter open Shutter fade, 100% (rapid - slow) Shutter closed Random shutter 100% (rapid - slow) Shutter open Random shutter 0% (rapid - slow) Shutter closed Random shutter fade, 0% (rapid- slow) Shutter open Random shutter fade, 100% (rapid- slow) Shutter open	000-015 016-095 096-110 111-111 112-125 126-126 127-126 128-142 143-143 144-158 159-159 160-174 175-175 176-190 191-191 192-206 207-207 208-222 223-223 224-238 239-239 240-254 255-255
7	7	<b>Dimmer 0 - 100%</b>	000-255
	8	<b>Fine dimmer (16Bit)</b>	
8	9	<b>Focus 0-100%</b>	000-255
	10	<b>Fine focus (16 Bit)</b>	000-255
9	11	<b>Zoom 0 -100% (near 7° - far 56°)</b>	000-255
	12	<b>Fine zoom (16 Bit)</b>	000-255
10	13	<b>Autofocus distance</b> Autofocus off Autofocus 0 m - 100 m	000-001 002-255
11	14	<b>Autofocus fine balancing</b> Autofocus fine balancing - 128 Middle position	000-255
12	15	<b>Iris 0-100% (open -&gt; closed)</b>	000-255
	16	<b>Fine iris (16Bit)</b>	
13	17	<b>Gobo wheel 1</b> Gobo 0  Gobo 1	 000-007  008-015

		Gobo 2		016-023
		Gobo 3		024-031
		Gobo 4		032-039
		Gobo 5		040-047
		Gobo 6		048-055
		Gobo 7		056-063
		Gobo 8		064-191
		Gobo wheel cycle, right (rapid - slow) Gobo wheel cycle, left (slow - rapid)		192-223 224-255
14	18	<b>Gobo wheel 2 - rotating gobos</b>		
		Gobo 0		000-007
		Gobo 1		008-015
		Gobo 2		016-023
		Gobo 3		024-031
		Gobo 4		032-039
		Gobo 5		040-047
		Gobo 6		048-255

# P 18 MK2 PROFILE

15	19	<b>Gobo positioning/rotation 2</b> Gobo positioning 0° - 540° Gobo rotation, right (rapid - slow) Stop gobo rotation Gobo rotation, left (slow - rapid)	000-191 192-222 223-224 225-255
	20	<b>Fine gobo positioning/rotation 2 (16 Bit)</b>	000-255
16	21	<b>Animation wheel</b> Open Faded water effect, middle position Stop faded water effect Faded water effect (slow -> rapid) Water effect switched, middle position Stop switched water effect Switched water effect (slow -> rapid) Faded fire effect, middle position Stop faded fire effect Faded fire effect (slow -> rapid) Switched fire effect, middle position Stop switched fire effect Switched fire effect (slow -> rapid)	000-000 001-001 002-002 003-063 064-064 065-065 066-127 128-128 129-129 130-191 192-192 193-193 194-255
17	22	<b>Aperture 1a 0-100%</b>	000-255
	23	<b>Aperture 1a fine (16 Bit)</b>	000-255
18	24	<b>Aperture 1b 0-100%</b>	000-255
	25	<b>Aperture 1b fine (16 Bit)</b>	000-255
19	26	<b>Aperture 2a 0-100%</b>	000-255
	27	<b>Aperture 2a fine (16 Bit)</b>	000-255
20	28	<b>Aperture 2b 0-100%</b>	000-255
	29	<b>Aperture 2b fine (16 Bit)</b>	000-255
21	30	<b>Aperture 3a 0-100%</b>	000-255
	31	<b>Aperture 3a fine (16 Bit)</b>	000-255
22	32	<b>Aperture 3b 0-100%</b>	000-255
	33	<b>Aperture 3b fine (16 Bit)</b>	000-255
23	34	<b>Aperture 4a 0-100%</b>	000-255
	35	<b>Aperture 4a fine (16 Bit)</b>	000-255
24	36	<b>Aperture 4b 0-100%</b>	000-255
	37	<b>Aperture 4b fine (16 Bit)</b>	000-255
25	38	<b>Aperture slider rotation -45° / +45°</b>	000-255

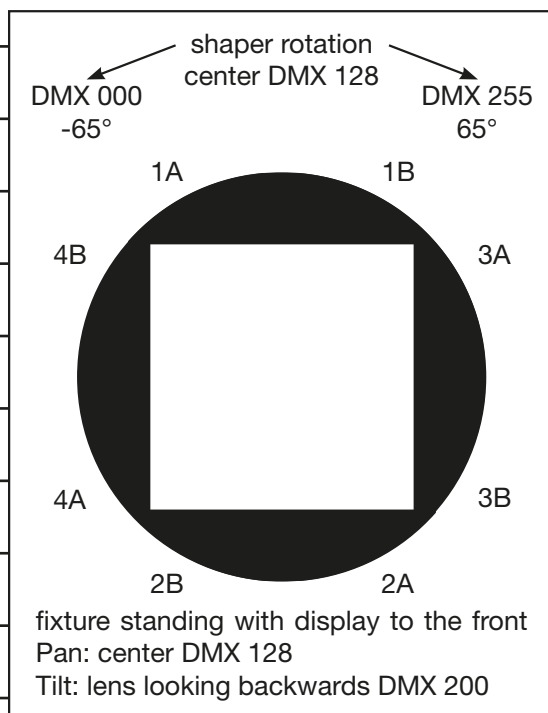

	39		<b>Fine aperture slider rotation</b> (16 Bit)	000-255
26	40		<b>Colour wheel</b> White White/Red Red Red/Yellow Yellow Yellow/Magenta Magenta Magenta/Green Green Green/Orange Orange Orange/Dark Blue Dark Blue Dark Blue/HCRI HCRI HCRI/White Linear colours: White - Red - Yellow - Magenta - Green - Orange - Dark Blue - HCRI - White Colour cycle, right (rapid - slow) Colour cycle, left (slow - rapid)	000-001 002-003 004-005 006-007 008-009 010-011 012-013 014-015 016-017 018-019 020-021 022-023 024-025 026-027 028-029 030-031 064-191 192-223 224-255
27	41		<b>Cyan</b> (8 Bit) 0-100%	000-255
	42		<b>Fine cyan</b> (16 Bit)	000-255
28	43		<b>Magenta</b> (8 Bit) 0-100%	000-255
	44		<b>Fine magenta</b> (16 Bit)	000-255
29	45		<b>Yellow</b> (8 Bit) 0-100%	000-255
	46		<b>Fine yellow</b> (16 Bit)	000-255
30	47		<b>CTO</b> (8 Bit) 0-100%	000-255
	48		<b>Fine CTO</b> (16 Bit)	000-255
31	49		<b>Sparkle - Glitter effect</b> Sparkle effect inactive Sparkle effect intensity (minimum - maximum)	000-000 001-255
32	50		<b>Sparkle speed</b> Faded sparkle effect (slow -> rapid) Switched sparkle effect (slow -> rapid) Repetition of the fading and switching blocks	000-031 032-063 064-255
33	51		<b>Prism 1</b> Open Prism 1 (5-fold linear)	000-007 008-255
34	52		<b>Prism 1 positioning/rotation</b> Prism positioning (0° - 540°) Prism rotation, right (rapid -> slow) Stop prism rotation Prism rotation, left (slow -> rapid)	000-191 192-222 223-224 225-255

# P 18 MK2 PROFILE

	53		<b>Prism 1 fine positioning/rotation</b> (16 Bit)	000-255
35	54		<b>Prism 2</b> Open Prism 2 (3-fold circular)	000-007 008-255
36	55		<b>Prism 2 positioning/rotation</b> Prism positioning (0° - 540°) Prism rotation, right (rapid -> slow) Stop prism rotation Prism rotation, left (slow -> rapid)	000-191 192-222 223-224 225-255
	56		<b>Prism 2 fine positioning/rotation</b> (16 Bit)	000-255
37	57		<b>Frost 1</b> Frost 0-100%	000-255
38	58		<b>Frost 2</b> Frost 0-100%	000-255
39	59		<b>Effects macro</b> Macro inactive Macro 001 - Macro 255	000-000 001-255
40	60		<b>Pan/tilt speed</b> Real-time motion Delayed motion (rapid - slow)	000-003 004-255
41	61		<b>Effects speed</b> Real-time effects Delayed effects (rapid - slow)	000-003 004-255
42	62		<b>Blackout Move</b> Not assigned Blackout during pan/tilt Blackout during Gobo, Colour, Prism, CMY, Iris, Frost Blackout during Gobo, Colour, Prism, CMY, Iris, Frost, Zoom, Focus Blackout during Gobo, Colour, Prism, CMY, Iris, Frost, Pan/Tilt Blackout during Gobo, Colour, Prism, CMY, Iris, Frost, Zoom, Focus, Pan/Tilt	000-095 096-127 128-159 160-191 192-223 224-255

## 6.1.3 Control channel

Via the control channel different functions of the fixture can be permanently switched. The following functions can be switched via the control channel.

- Response of the headlamp when dimming via faders
- BACKLIGHT MODE - display backlight
- DISPLAY ORIENTATION - display orientation
- MAIN SCREEN MODE - main screen view
- USER FIXTURE ID SET - set headlight number
- DIMMER CURVE - dimmer curve adjustment
- RGB / CMY CURVE - adjust the RGB / CMY curve
- FROST CURVE - setting the frost curve
- PAN / TILT SPEED - pan / tilt speed
- EFFECT SPEED - effect speed
- LED FADE OUT MODE - type of dimming
- COOLING MODE - adjust the fan volume and brightness
- CAMERA MODE - sets the LED refresh rate
- RESET - a basic reset of the headlight is performed

For details, see DMX Channel functions for the P18 Profile MK2 on page 24.

## 6.1.4 Sparkle effect, sparkle speed

Animation effects can be created via this channel in connection with the focus. Depending on the intensity, the projection can be made to shake more or less. This effect can be dimmed or switched.

## 6.1.5 Auto focus

To activate the autofocus function, set the autofocus distance channel to around 50%. Then best use gobo wheel 2 for fine adjustment of the system and set the focus accordingly to 125 (32000): Then set the distance to the headlight by focusing the headlight using the autofocus distance. As a guideline, DMX value divided by 10 corresponds to the distance (DMX 100/10 distance = 10m). Now the headlight can be operated with autofocus via the zoom. Using the following table, the focus values for the individual effects can now be preselected and zoomed in with autofocus.

	Animation	Gobo1	Gobo2	Open	Shaper	Iris
Focus 8Bit	55	95	145	185	195	215
Focus 16Bit	14080	24320	37120	47360	49920	55040

## 6.2 Artnet

The spotlight can be controlled via Artnet - ArtNET 4. To do this, set the Artnet address via the menu item DMX / NET ADDR -> ARTNET ADDRESS and also select it via the menu item PERSONALITY -> DMX INPUT CONFIG -> NETWORK -> MODE -> ARTNET. In addition, define the IP address of the spotlight via PERSONALITY -> DMX INPUT CONFIG -> NETWORK -> IP ADDRESS.

## 6.3 Streaming ACN

The headlight can be controlled via sACN - Streaming ACN. To do this, set the sACN address via the menu item DMX / NET ADDR -> SACN ADDRESS and also select it via the menu item PERSONALITY -> DMX INPUT CONFIG -> NETWORK -> MODE -> SACN. In addition, define the IP address of the spotlight via PERSONALITY -> DMX INPUT CONFIG -> NETWORK -> IP ADDRESS.

# P18 MK2 PROFILE

## 6.4 Wireless-DMX

The P18 MK2 Profile is equipped with a Lumen Radio CRMX receiver for wireless DMX. The receiver can process both DMX and RDM. If there is a cable and wireless connection to the P18, the cable connection has priority! The received signal can be output via the DMX connection. To do this, set the DMX OUTPUT CONFIG setting to ON in the PERSONALITY menu. After confirming with ENTER, the spotlight will output the entire universe received via wireless DMX.

## 6.5 RDM

The P18 MK2 Profile can communicate via RDM (Remote Device Management) in accordance with ESTA American National Standard E1.20-2006. RDM is a bidirectional communication protocol for use in DMX512 control systems. It is the open standard for the configuration and status monitoring of DMX-512 devices. The RDM protocol enables data packets to be inserted into a DMX-512 data stream without affecting existing non-RDM devices. It enables a console or dedicated RDM controller to send commands to specific devices and receive messages. The P18 MK2 Profile can send and receive RDM via DMX and Artnet 4. The spotlight is also designed to send RDM via sACN and receive it via Artnet. The RDM functionality depends on the lighting control desk used, the operating instructions of the respective desk manufacturer must also be observed.

### 6.5.1 RDM-UID

Every P18 MK2 Profile has a factory-set RDM-UID (unique identification number), which makes it addressable and identifiable in RDM systems.

### 6.5.2 RDM-PIDs

The P18 MK2 Profile supports the RDM PIDs (parameter IDs) required by ESTA as well as manufacturer-specific PIDs.

### 6.5.3 Standard RDM parameter IDs

RDM parameter ID	GET	SET	DISCO- VERY	Note
RDM identification				
DISC_UNIQUE_BRANCH			✓	is used for fixture identification
DISC_MUTE			✓	is used for fixture identification
DISC_UN_MUTE			✓	is used for fixture identification
RDM status determination				
QUEUED_MESSAGE	✓			
STATUS_MESSAGES	✓			
STATUS_ID_DESCRIPTION	✓			
CLEAR_STATUS_ID		✓		
RDM information				
SUPPORTED_PARAMETERS	✓			
RDM configuration				
DEVICE_MODEL_DESCRIPTION	✓			
MANUFACTURER_LABEL	✓			
FACTORY_DEFAULTS		✓		
SOFTWARE_VERSION_LABEL	✓			
DMX_PERSONALITY		✓		
DMX_PERSONALITY_DESCRIPTION	✓			
DMX_START_ADDRESS		✓		
SENSOR_DEFINITION	✓			



DEVICE_HOURS	✓			
LAMP_HOURS	✓			
IDENTIFY_DEVICE		✓		
RESET_DEVICE		✓		
PERFORM_SELFTEST		✓		
SELFTEST_DESCRIPTION	✓			

## 6.5.4 Manufacturer specific RDM parameter IDs

RDM parameter ID	GET	SET	DISCO- VERY	Note
RDM configuration				
Battery Charge Hours	✓			
Error Number	✓			
Error	✓			
Select Next Error		✓		
Remove Error		✓		
Remove New Error Flag		✓		
User Defaults		✓		
User Fixture ID		✓		
Fixture Lock On/Off	✓	✓		
Dimmer Curve	✓	✓		
RGB Curve	✓	✓		
Frost Curve	✓	✓		
Camera Mode	✓	✓		
Cooling Mode	✓	✓		
Pan Tilt Speed	✓	✓		
Effect Speed	✓	✓		
Backlight Mode	✓	✓		
Disp Orientation	✓	✓		
Main Screen Mode	✓	✓		
Safe Mode Switch	✓	✓		
LED Fade Out Mode	✓	✓		
Blade Mode	✓	✓		

## 6.5.5 RDM sensor IDs

RDM sensor ID	GET	SET	DISCO- VERY	Note
RDM sensors				
Temp Sens Base LCD	✓	✓		
Temp Sens Base PS	✓	✓		
Temp Sens Head PCB	✓	✓		
Temp Sens Head Drv	✓	✓		
Temp Sens Head LED	✓	✓		
Temp Sens Head Air	✓	✓		





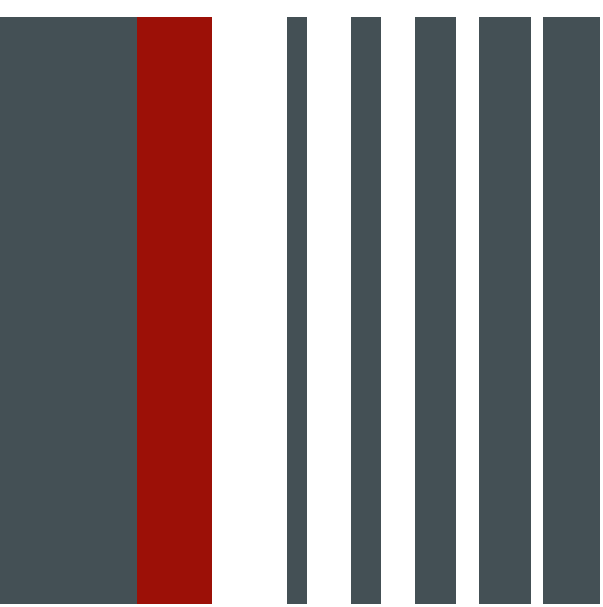

JB-Lighting Lichtanlagentechnik GmbH  
Sallersteig 15  
89134 Blaustein  
Tel. +49 7304 9617-0  
Fax. +49 7304 9617-99  
info@jb-lighting.de  
www.jb-lighting.de

**JB LIGHTING**