

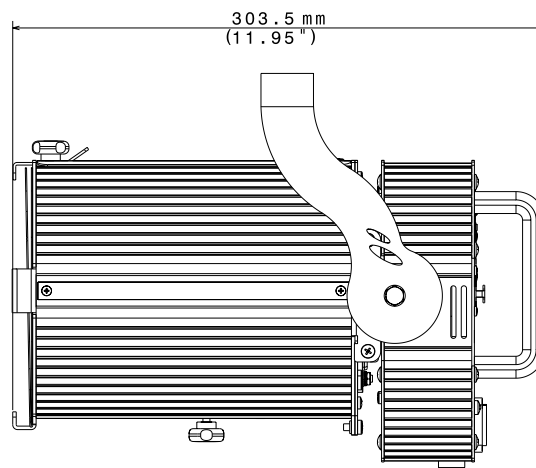

SCENA LED 80 CT

THE SMART REPLACEMENT OF THE CONVENTIONAL 1000 W
THEATRE LIGHTS WITH SELECTABLE COLOR TEMPERATURE

SCENA LED 80 CT is a **compact, lightweight, DMX-controlled LED projector** equipped with an high-power **Tunable WHITE LED 2700K ÷ 6000K featuring 2 LED channels** (Warm White / Cold White); 9,200 Lumens. The unit features a \varnothing 112 mm Fresnel lens, and a long excursion **14°-77° linear zoom** with high-efficiency optical system. The fixture doesn't heat up and **the projection is always flicker free**. The dimming curves are similar to those of halogen lamps. The panel connectors are PowerCON In&Out and XLR 5 pins In&Out. SCENA LED 80 FC is contained in a strong housing with folded edges, designed to resist all the rigors of continuous use. Also, the yoke has an exclusive round flange + clutch system which guarantees a perfect grip and safer operation. Thanks to a dedicated kit is possible to instal the fixture on electrified rails.

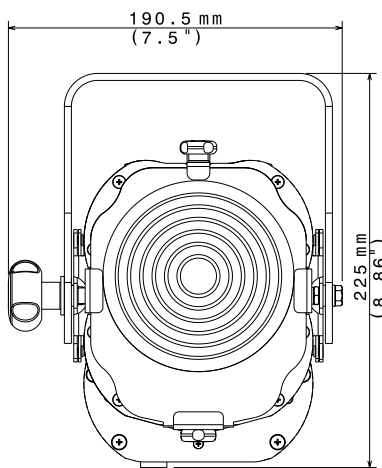

03.TS047.46.F

MOTORIZED ZOOM VERSION AVAILABLE ON DEMAND

OUTPUT

- Single high-power white LED with linearly tunable color temperature (2700 K - 6000 K)
- CRI > 80
- LED lifespan: 50,000 hours (70% lumen output)

OPTICAL GROUP

- Ø 112 mm Fresnel lens
- 14° - 77° linear zoom

CONTROL

- DMX 512 / RDM or Manual control

- 7 DMX channels (default); 2 DMX channels or “CTC” mode
- 4-digit 7-segment LED display + 4 soft keys
- Internal operating system updatable via DTS dongle firmware uploader

POWER SUPPLY

- Full-range 100-240Vac 50-60 Hz
- Power consumption: 100 W max
- Power Factor: PF >0.95

CONNECTIONS

- Power supply: PowerCON In&Out panel connectors
- DMX: XLR 5-pole In&Out panel connectors

INTERNAL SAFETY DEVICES

Overvoltage and overtemperature circuits protection

OPERATING TEMPERATURE

-10° / 40° C

PHYSICAL

- IP20
- Weight: 4.1 Kg (9 lbs)
- Finishing: Black

SHIPPING

- Packaging: Carton box
- Box size (LxHxD): 230 x 370 x 230 mm (9.1" x 10.6" x 9.1")
- Weight: 5.1 Kg (11.2 lbs)

ACCESSORIES INCLUDED

- 1 x PowerCON female cable connector (code 0520P014)
- 1 x XLR 5 pins male cable connector (code 0508B028)
- 1 x XLR 5 pins female cable connector (code 0508B027)
- 1 x FilterframeBlack finishing - already installed on the projector (code 02M00422.46)

ACCESSORIES ON REQUEST

- Barndoor Black finishing (code 03.TA206)
- G50 “C” Clamp - max. Load 10 Kg (code 0521A012)
- G60 “C” Clamp - max. Load 50 Kg (code 0521A004)
- Safety cable - 0.3x60 cm - max. capacity load 60 Kg (code 0521A010)
- DTS dongle firmware uploader (code 03.LA.206)

ACCESSORIES FOR ELECTRIFIED RAIL MOUNTING

- Track adapter - black finishing (code 03.LA.235)

PHOTOMETRIC DATA

	mt 2 ft 6.56	mt 4 ft 13.12	mt 6 ft 19.68	mt 8 ft 26.25	mt 10 ft 32.81
BEAM ANGLE 14° @ 50%					
lux center (lx)	9094	2273	1010	568	364
foot candles (fc)	845	211	94	53	34
diameter (cm)	49	98	147	196	246
diameter (ft)	1.61	3.22	4.83	6.45	8.06
BEAM ANGLE 77° @ 10%					
lux center (lx)	1500	375	167	94	60
foot candles (fc)	139	35	15	9	6
diameter (cm)	318	636	955	1273	1591
diameter (ft)	10.44	20.88	31.32	41.75	52.19