

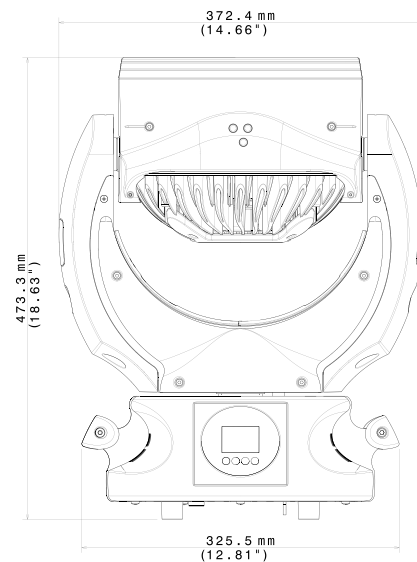

# NICK NRG 1401

THE CREATIVE BEAM / WASH LED LIGHT  
WITH SINGLE PIXEL CONTROL

NICK NRG 1401 is a **high performance LED wash moving head**. **Extreme brightness, single pixel control**, and **4° to 52° zoom range** make this fixture perfect in a range of applications, either as a beam light with multi-color rays, or as a wash light with a very wide projection. NICK NRG 1401 is **suitable for medium/big venues**, and it's the perfect solution for TV studios, delivering top-of-the-line visual effects or perfectly uniform wash lighting. NICK NRG 1401 is equipped with 23 high power OSTAR STAGE N RGBW LEDs.

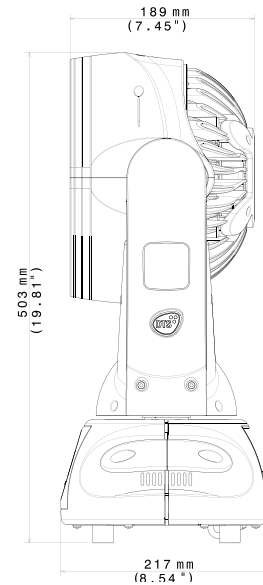

03.LDR015.FFP

### OUTPUT

- 23 x 20 W Full Color (RGBW) LEDs
- Pixel to pixel control (11,500 Lumens)

### OPTICAL GROUP

- 4°- 52° linear motorized zoom with high efficiency optical system
- 27,000 Lux at 5 m
- PC Beam to very wide Wash projections

### COLOR GENERATION

- 16 million colors
- Wide palette of pure uniform whites
- Variable linear color temperature (2700K – 8000K)

### CONTROL

- Multi-function OLED graphic color display + 4 soft keys: control / management / monitoring of the main parameters
- Controlled via DMX 512 and RDM standard digital communication protocols
- Internal operating system updatable via DTS dongle firmware uploader

### DMX

- 33 DMX channels (default)
- 111 DMX channels
- 31 DMX channels
- 20 DMX channels

### PAN & TILT

- ‘FPR’ system (DTS patent)
- Pan: limitless rotation, in both directions
- Tilt 258°: 1.1 sec.
- 16-bit movement resolution

### POWER SUPPLY

- Electronic full-range 100-240Vac 50-60 Hz
- Power consumption: 390 W
- Power Factor: PF >0.95

### CONNECTIONS

- DMX: XLR 3-pole In/Out and 5-pole In/Out panel connectors
- Power supply: PowerCON In/Out panel connectors

### INTERNAL SAFETY DEVICES

Overvoltage and overtemperature circuits protection

### OPERATING TEMPERATURE

-10° / 40° C

### PHYSICAL

- IP20
- Weight: 13 Kg (28.7 lbs)
- Finishing: Black

### SHIPPING

- Packaging: Carton box
- Box size: 440 x 420 x 540 mm (17.3" x 16.5" x 21.3")
- Box weight: 15.6 Kg (34.4 lbs)

### ACCESSORIES INCLUDED

- 1 x PowerCON female cable connector (code 0520P014)
- 1 x XLR 5 Pins female cable connector (code 0508B147)
- 1 x XLR 5 Pins male cable connector (code 0508B148)
- 1 x omega bracket with “Fast Lock” connection 1/4 turn (code 02K00467)

### ACCESSORIES ON REQUEST

- Flightcase for 4 units (code 0521C059.1)
- G60 “C” Clamp - max. load 50 Kg (code 0521A004)
- Aliscaf clamp for tube diameter 50 mm - max. load 200 Kg (code 0521A033)
- G-QUICK clamp Professional - max. load 100 Kg (code 0521A037)
- Safety cable - 0.3x60 cm - max. capacity load 60 Kg (code 0521A010)
- DTS dongle firmware uploader (code 03.LA.206)

### PHOTOMETRIC DATA

	mt 5 ft 16.40	mt 10 ft 32.81	mt 15 ft 49.21	mt 20 ft 65.62	mt 25 ft 82.02
<b>BEAM ANGLE 4°</b>					
lux center (lx)	27000	6750	3000	1688	1080
foot candles (fc)	2509	627	279	157	100
diameter (cm)	35	70	105	140	175
diameter (ft)	1.15	2.29	3.44	4.58	5.73

	mt 5 ft 16.40	mt 10 ft 32.81	mt 15 ft 49.21	mt 20 ft 65.62	mt 25 ft 82.02
<b>BEAM ANGLE 52°</b>					
lux center (lx)	804	201	89	50	32
foot candles (fc)	75	19	8	5	3
diameter (cm)	488	975	1463	1951	2439
diameter (ft)	16.00	32.00	48.00	64.01	80.01