

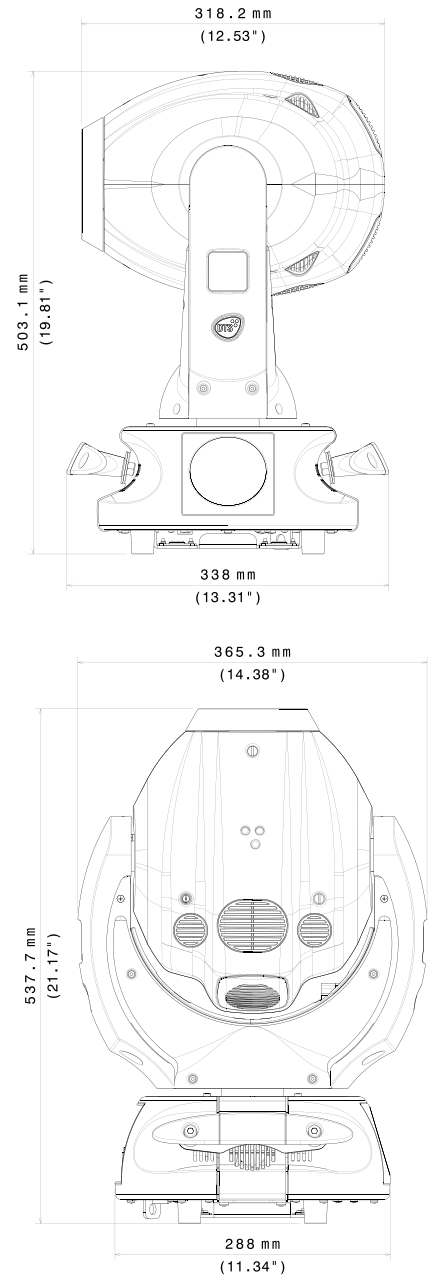

# RAPTOR

## ULTRA BRIGHT, FAST MOVEMENT BEAM MOVING HEAD

RAPTOR is the **brightest and most compact BEAM moving head** on the market. Thanks to its exclusive **'FPR' system** and its unique **8-facet prism**, RAPTOR is extremely versatile in any event as an **effect projector** or as a **searchlight**. RAPTOR is equipped with an HRI 330 W LAMP which delivers 16,500 Lumens.



03.MB005.EB.LFP

### OUTPUT

- Lamp: Osram Sirius HRI 330 W (16,500 Lumens)
- Color temperature: 7500K

### OPTICAL GROUP

- Beam opening: 3.4°
- 156,800 Lux / 15 m
- 16-bit motorized linear focus
- Linear dimmer / shutter / ultra-fast strobe

### COLOR GENERATION

- 17-color wheel with linear selection for perfect 2-color beams

### DYNAMIC EFFECTS

- 17-gobo wheel
- 8-facet rotating prism

### FILTERS

- Smooth filter (eliminates the hot spot, evenly diffusing luminosity)
- Frost filter

### CONTROL

- LCD graphic display (control / management / monitoring of the main parameters) + 4 soft-keys
- Controlled via DMX 512 and RDM standard digital communication protocols
- Internal operating system updatable via DTS dongle firmware uploader

### DMX

- 18 DMX channels (default)
- 20 DMX channels

### PAN & TILT

- 'FPR' system (DTS patent)
- Pan: limitless rotation, in both directions
- Tilt 240°: 1.2 sec.
- Tri-phase stepper motor technology for ultra-fast silent movements
- 16-bit resolution
- Selectable speed ranges

### POWER SUPPLY

- Electronic full-range 100-240Vac 50-60 Hz
- Power consumption: 450 W with PFC
- Power Factor: PF >0.90

### CONNECTIONS

- DMX: XLR 3-pole In/Out and 5-pole In/Out panel connectors
- Power supply: PowerCON In/

Out panel connectors

### INTERNAL SAFETY DEVICES

Overvoltage and overtemperature circuits protection

### OPERATING TEMPERATURE

-10° / 40°C

### PHYSICAL

- IP20
- Weight: 16.8 Kg (37 lbs)
- Finishing: Black

### SHIPPING

- Packaging: Carton box
- Box size: 590 x 420 x 440 mm (23.2" x 16.5" x 17.3")
- Box weight: 20.3 Kg (44.7 lbs)

### ACCESSORIES INCLUDED

- 1 x PowerCON female cable connector (code 0520P014)
- 1 x XLR 5 Pins male cable connector (code 0508B148)
- 1 x XLR 5 Pins female cable connector (code 0508B147)
- 2 x Omega Bracket with "Fast Lock" connection 1/4 turn (code 02K00549)

### ACCESSORIES ON REQUEST

- Lamp OSRAM SIRIUS HRI 330 W (code 0505S037)
- Flightcase for 4 units (code 0521C059.1)
- Aliscaf clamp for tube diameter 50 mm - max. load 200 Kg (code 0521A033)
- G-QUICK clamp Professional - max. load 100 Kg (code 0521A037)
- G60 "C" clamp - max. load 50 Kg (code 0521A004)
- Safety cable - 0.3x60 cm - max. capacity load 60 Kg (code 0521A010)
- DTS dongle firmware uploader (code 03.LA.206)

### FIXED GOBO WHEEL

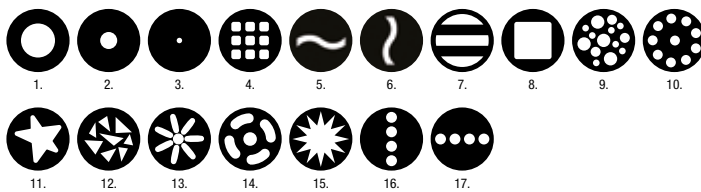

### COLOR WHEEL

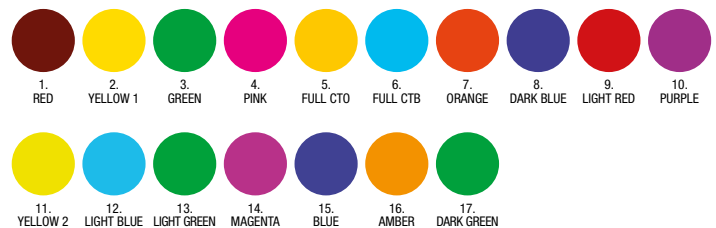

### PHOTOMETRIC DATA

	mt 5 ft 16.40	mt 15 ft 49.21	mt 25 ft 82.02	mt 50 ft 164.04	mt 100 ft 328.08
<b>lux center (lx)</b>	1411200	156800	56448	14112	3528
<b>foot candles (fc)</b>	131152	14572	5246	1312	328
<b>diameter (cm)</b>	30	89	148	297	594
<b>diameter (ft)</b>	0.97	2.92	4.87	9.74	19.47

BEAM ANGLE 3.4°