

# EXPOLITE

## Tour-LED MC 60

# Bedienungsanleitung User Manual ab Firmware V1XX

Art.Nr.: led25100

Eigenschaften  
Bedienelemente  
Steuerung

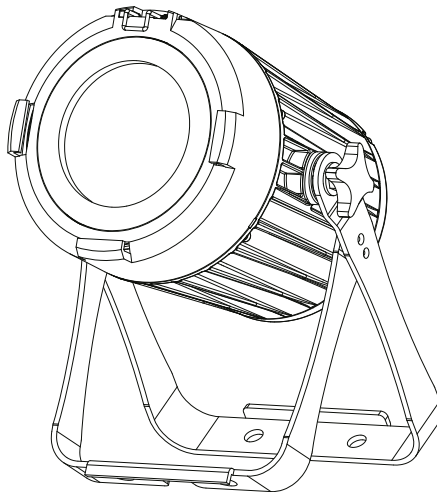

Specifications  
Menu  
Control

Bedienungsanleitung bitte aufbewahren  
Keep this Manual for later queries

Änderungen sind ohne Ankündigung möglich.  
Changes are possible without prior notice.  
Rev. 2018-43-11



Die beiliegenden Bedienhinweise für Expolite Geräte sind Bestandteil dieser Bedienungsanleitung. Lesen Sie diese sorgfältig, bevor Sie das Gerät in Betrieb nehmen.

The enclosed General Information for Expolite Units are part of these user manual. Read them carefully before operating the device.



by

**FOCON SHOWTECHNIC**  
Vertriebsgesellschaft mbH  
Teichweg 4+6  
D-49504 Lotte/Wersen

Telefon: ++49 (0) 541-77095-0  
Fax: ++49 (0) 541-77095-27

[info@focon-showtechnic.com](mailto:info@focon-showtechnic.com)  
[www.focon-showtechnic.com](http://www.focon-showtechnic.com)



# Inhalt - Content

	Inhalt - Content	Seite / Page
DE	Lieferumfang	D-04
	Technische Daten	D-05
	Abmessungen	D-06
	Installation	D-07
	Bedienung	D-08
	Steuerung mit DMX512	D-14
ENG	Delivery	E-20
	Product Information	E-21
	Dimensions	E-22
	Installation	E-23
	Operation	E-24
	Using DMX512 Controller	E-30



## Lieferumfang

- Expolite Tour-LED MC 60
- Anschlusskabel für Spannungsversorgung
- Bedienhinweise für Expolite Geräte
- Bedienungsanleitung

Expolite Geräte werden vor dem Versand sorgfältig geprüft. Sollte der Lieferumfang dennoch nicht vollständig sein, wenden Sie sich bitte umgehend an Ihren Vertriebspartner.

## Technische Daten

Spannungsversorgung	100V - 240V AC 50/60Hz
Maximale Leistungsaufnahme	85W
Abmessungen	348 x 176 x 242mm
Gewicht	5,4kg
Anschlüsse	Power In/Out   DMX In/Out
Betriebstemperatur	-20°C - 45°C
Luftfeuchtigkeit*	< 80%
Schutzklasse	IP 65
Gehäuse	Aluminiumdruckguss Gehäuse
LEDs	1x 60W RGBW**
LED Treiberstrom	4,5A
Abstrahlwinkel	4,5° - 45°
Steuerung	Stand-Alone / DMX512
DMX-Kanäle	9 - 17 (9/9/12/17)

\* Siehe Allgemeine Bedienhinweise für Expolite Geräte - Hinweise zu Kondenswasserbildung im Geräteinneren

\*\* Toleranzbereich der Farbtemperatur entsprechend Herstellerangabe +/- 10%.

### ILLUMINANCE AT DISTANCE

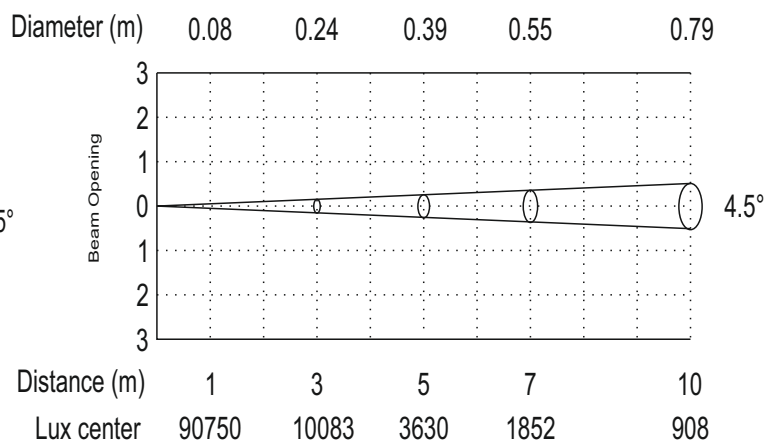
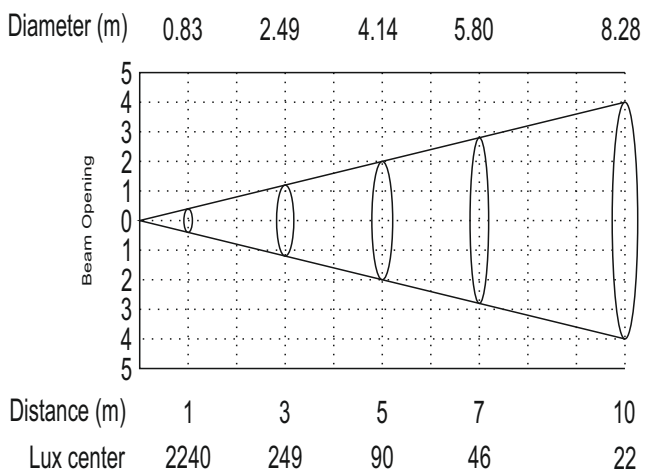

## Abmessungen

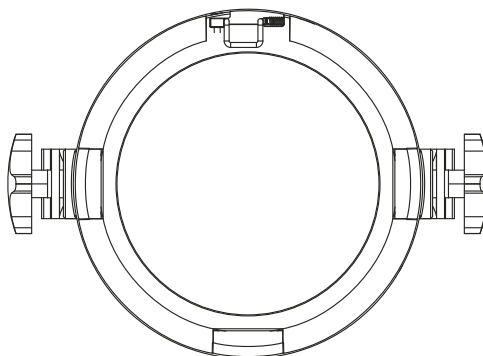
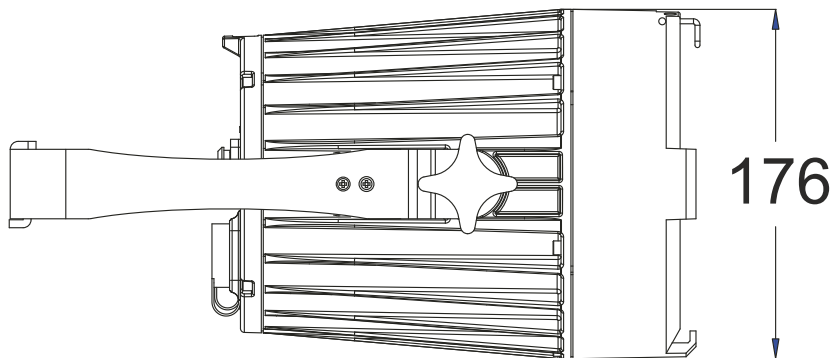
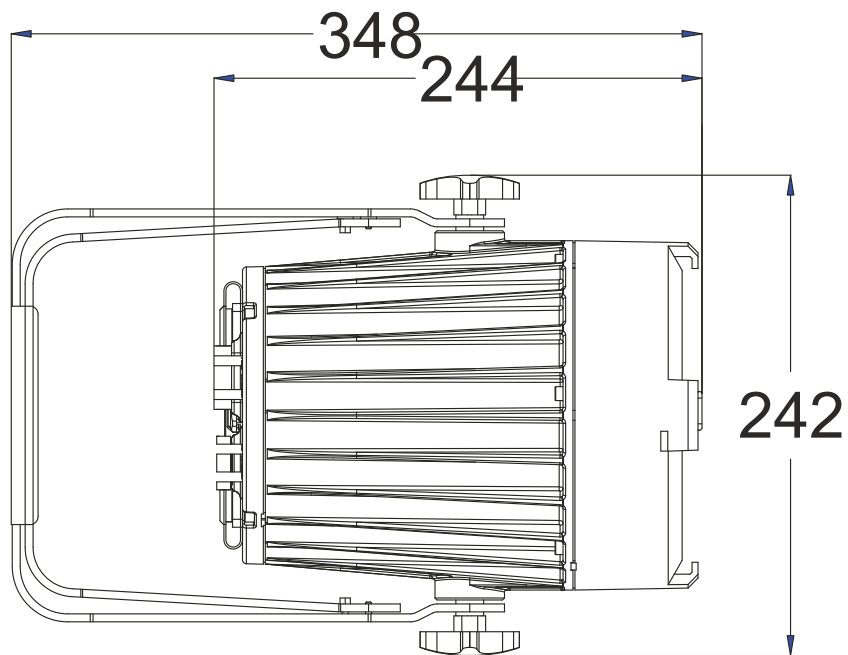

## Installation

### Montage

#### Hängend

Das Gerät kann in jeder beliebigen Position verwendet werden. An dem Montagebügel sind Bohrungen vorhanden, durch die gängige Halterungen sicher montiert werden können. Geräte müssen entsprechend der jeweils gültigen Vorschriften sicher montiert und mit einer zweiten Sicherung gegen herabfallen versehen werden. Hierzu ist am Gerät eine Öse für Safeties angebracht.

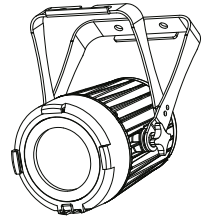

#### Stehend

Das Gerät kann direkt auf den montierten Bügel gestellt werden. Hierzu muss dieser bis in den mechanischen Anschlag aufgeklappt werden.

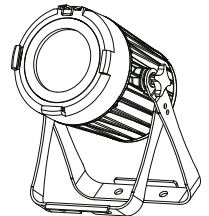

### HINWEIS

Das LED Modul kann in jeder beliebigen Lage betrieben werden.

### Verbindung der Spannungsversorgung

Bei 230V Netzspannung: maximal 20 Geräte in Reihe.

Bei 120V Netzspannung: maximal 10 Geräte in Reihe.

### DMX-Verbindung

Die Geräte mit geeigneten DMX-Kabeln miteinander und mit dem Controller verbinden. Die vorgesehenen DMX-Adressen und Personalities an den Geräten einstellen.

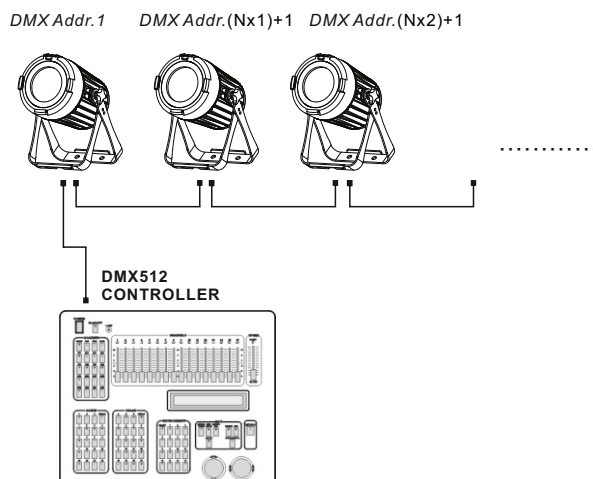

## Bedienung

### Bedienelemente am Gerät

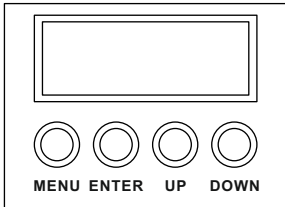

MENU - Taste: Eine Menüebene aufwärts  
 ENTER-Taste: In gewähltes Menü springen; Eingabe bestätigen  
 UP-Taste: Aufwärts blättern; Wert erhöhen  
 DOWN-Taste: Abwärts blättern; Wert verringern

### Menüstruktur

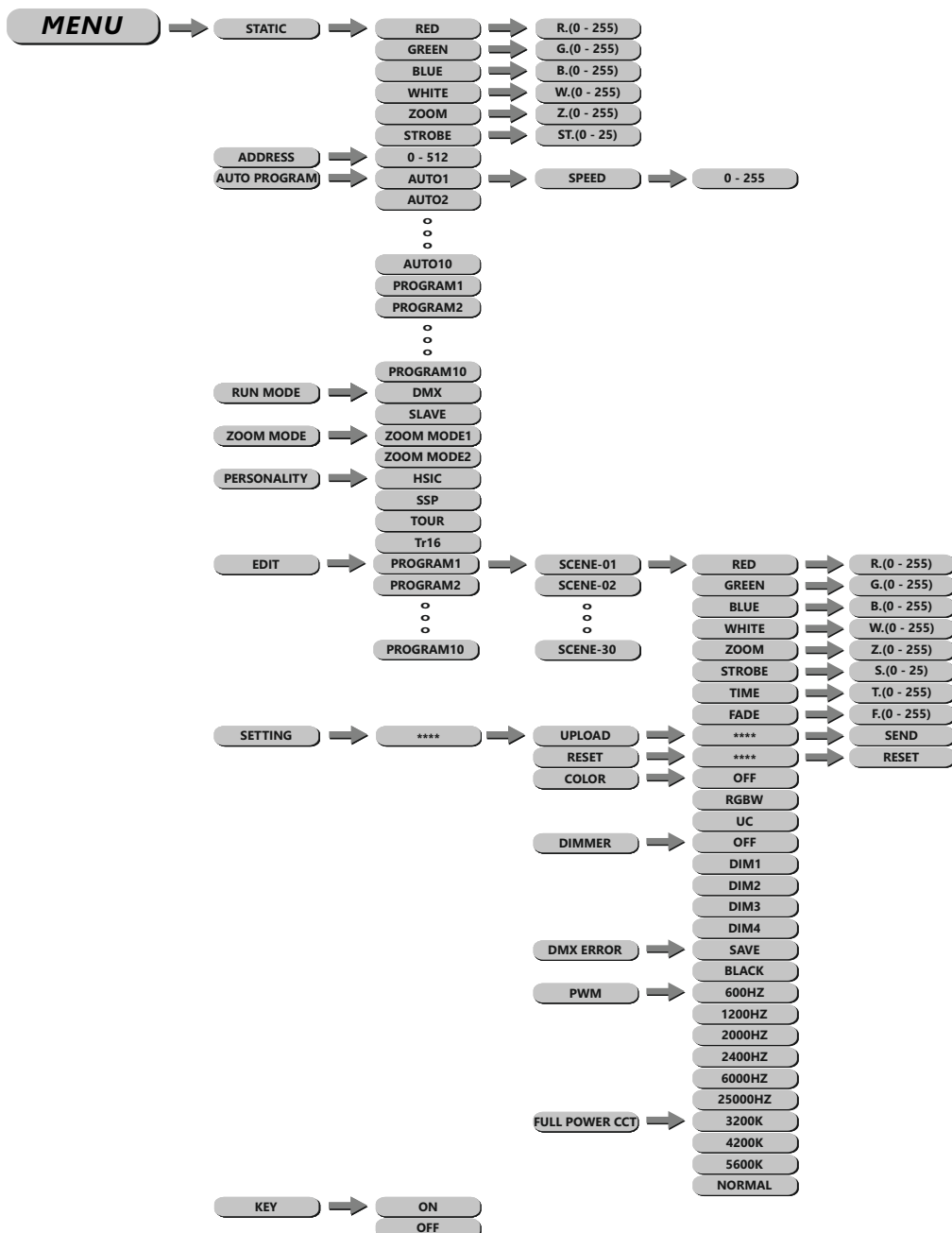



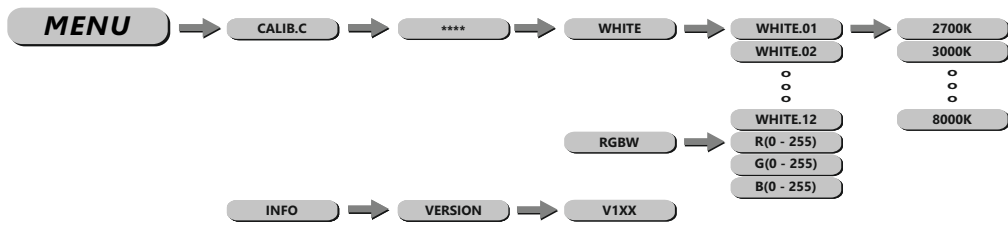

## DMX-Adresse einstellen



Im Menü wird im Punkt **ADDRESS** die DMX-Startadresse des Gerätes eingestellt. Diese bleibt auch bei dem Wechsel der Personality erhalten.

## DMX-Kanalbelegung einstellen



Im Menü **PERSONALITY** wird die Belegung der DMX-Kanäle des Gerätes festgelegt. Es stehen die Modi **HSIC** (9 Kanäle), **SSP** (9 Kanäle), **TOUR** (12 Kanäle) und **Tr16** (17 Kanäle) zur Verfügung.

## Statische Farbe einstellen

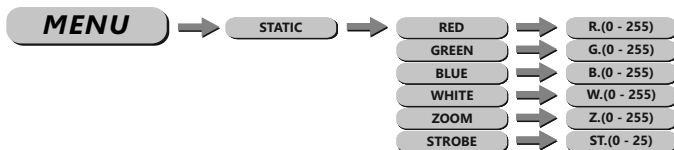

Im Menü werden im Punkt **STATIC** statische Farben für den Stand-Alone Betrieb eingestellt. Diese werden anhand der DMX-Werteskala 0-255 für Rot (**RED**), Grün (**GREEN**), Blau (**BLUE**), Weiß (**WHITE**) und dem Zoom (**ZOOM**), sowie dem Stroboskopwert 0-25Hz (**STROBE**) gemischt.

## Automatikprogramme abspielen

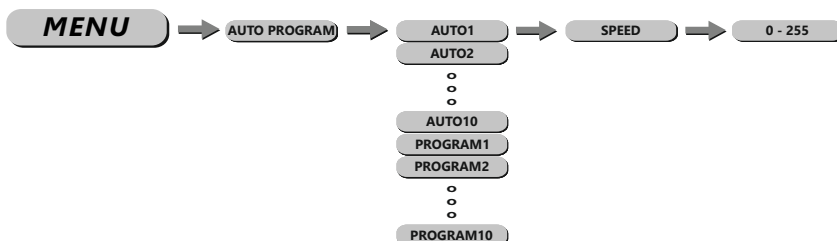

# EXPOLITE

Im Menü werden im Punkt **AUTO PROGRAM** die im Gerät gespeicherten Automatikprogramme abgespielt. Die Programme **AUTO01** bis **AUTO10** sind fest im Gerät hinterlegt. Die Programme **PROGRAM1** bis **PROGRAM10** sind editierbar. Dies wird unter **Editieren benutzerdefinierter Programme** beschrieben. Automatikprogramme werden als Master an verbundene Slave-Geräte übertragen. Für den Master-Slave-Betrieb werden Signale über die DMX-Leitung gesendet. Dies kann dritte Geräte stören.

## Zoommode auswählen



Im Menü **ZOOM MODE** wird die Geschwindigkeit des motorischen Zooms eingestellt. Im **ZOOM MODE1** fährt der Zoom mit maximaler Geschwindigkeit, im **ZOOM MODE2** fährt der Zoom mit reduzierter Geschwindigkeit und geringerer Lautstärke.

## Runmode auswählen



Im Menü **RUN MODE** wird der Betriebsmodus eingestellt. Für den Betrieb an einem DMX-Kontroller muss **DMX** aktiviert werden. Im Modus **SLAVE** wird das Gerät von einem Master-Gerät gesteuert.

## Editieren benutzerdefinierter Programme

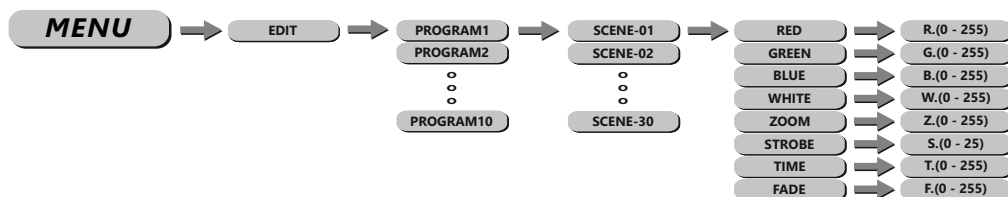

Im Menü **EDIT** werden die Benutzerprogramme **PROGRAM1** bis **PROGRAM10** editiert. Jedes Programm kann aus bis zu 30 Schritten bestehen (**SCENE-01** - **SCENE-30**). Jeder Schritt besteht aus den Parametern Farbe **RGBW**, Stroboskop (**STROBE**) „0-25Hz“, Dauer des Steps (**TIME**) und Überblendzeit (**FADE**). Benutzerprogramme können auf andere Geräte überspielt werden, siehe Master-/Slave Menü.

**HINWEIS:** Für weniger als 30 Schritte müssen **TIME** und **FADE** des letzten Schrittes auf 0 gesetzt werden.

Beispiel für Time-Settings eines Stand-Alone Programmes mit 3 Schritten:

Step 1 **TIME** = 4    **FADE** = 3  
Step 2 **TIME** = 5    **FADE** = 2  
Step 3 **TIME** = 0    **FADE** = 0

## Verschiedene Einstellungen

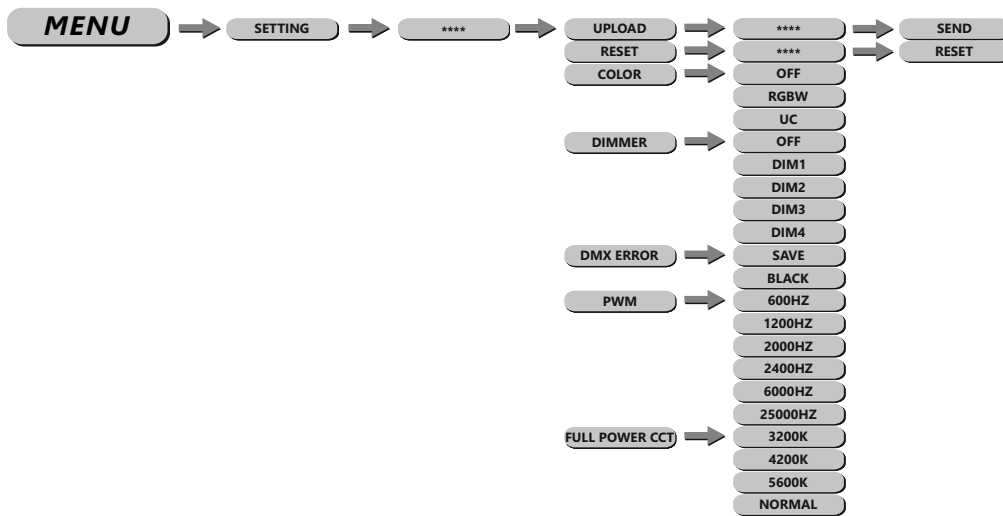

Das Passwort lautet: **UP - DOWN - UP - DOWN - ENTER**

**UPLOAD:** sendet die benutzerdefinierten Programme an verbundene Slave-Geräte.

**RESET:** setzt die editierbaren Einstellungen zurück auf die Werkseinstellungen.

**COLOR:** bietet die Möglichkeit eine Farbkalibrierung auszuwählen. Unter **UC** wird der Uniform-Color-Modus aktiviert, der die werkseitige Angleichung aller Geräte der Tour-LED Familie abrufen. Unter **RGBW** werden die unter **CALIB.C\RGBW** eingestellten Werte verwendet. Bei **OFF** wird keine Kalibrierung genutzt. So erreicht das Gerät die maximale Helligkeit.

**DIMMER:** stellt die gewünschte Dimmkurve zur Simulation eines Halogenleuchtmittels ein (**OFF/DIM1/DIM2/DIM3/DIM4**).

**DMX ERROR:** stellt das Verhalten bei Unterbrechung des DMX-Signals ein. **SAVE** um den letzten empfangenen Wert zu halten, oder **BLACK** für Blackout.

**PWM:** bietet die Möglichkeit die PWM-Frequenz des Gerätes anzupassen (**600HZ/1200HZ/2000HZ/2400HZ/6000HZ/25000HZ**).

**FULL POWER CCT:** wählt die Farbtemperatur bei vollem Output. **3200K/4200K/5600K/10000K** und **NORMAL** können eingestellt werden.

## Aktivieren des Passwortschutzes



Im Menüpunkt **KEY** wird der Passwortschutz des Gerätes bei Gerätestart aktiviert oder deaktiviert. Wenn **KEY** auf **ON** gestellt ist, startet das Gerät gesperrt und das Menü wird jeweils 30 Sekunden nach der letzten Eingabe erneut gesperrt. Für Änderungen im Menü muss dann das Passwort **UP - DOWN - UP - DOWN - ENTER** eingegeben werden.

## Kalibrierung und Weißabgleich

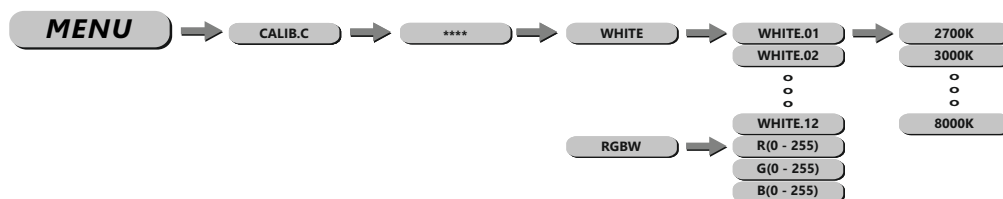

Im Menü **CALIB.C** werden die Weißkalibrierungen eingestellt.

Im Untermenü **WHITE** können die vorprogrammierten Farbtemperaturen geändert werden.

Untermenü **RGBW** wird der Weißwert für die Eingabe der maximalen DMX-Werte eingestellt. Wenn diese Kalibrierung aktiviert ist und das Gerät die DMX-Werte RGB = 255, 255, 255 empfängt, wird das hier hinterlegte Weiß ausgegeben.

**HINWEIS:** Der Maximalwert kann auf „0“ begrenzt werden. In diesem Fall reagiert ein Farbkanal nicht auf einen gesendeten DMX-Wert. Dies kann als Gerätefehler fehlinterpretiert werden.

## Info-Menü



Im Info-Menü (**INFO**), Untermenü **VERS** wird die z.Zt. installierte Firmwareversion des Gerätes angezeigt.

## Steuerung mit DMX512

### DMX-Kanalbelegung

Dieses Gerät verfügt über verschiedene DMX-Personalities. Bei diesen werden unterschiedlich viele DMX-Kanäle belegt und die Reaktion des Gerätes unterscheidet sich entsprechend.

Es sind 4 DMX-Personalities (9-/9-/12-/17-Kanäle) wählbar.

Durch Änderungen in der Gerätesoftware kann es zu weiteren oder geänderten Funktionen kommen.

Auf der Website steht das aktuellste Dokument „DMX-Channels“ als pdf zum Download zur Verfügung.

HSIC		
1	0-255	Intensity
2	0-255	Hue
3	0-255	Hue Fine
4	0-255	Saturation
5		CCT
	0-10	No Function
	11-30	2700K
	31-50	3000K
	51-70	3200K
	71-90	3500K
	91-110	4000K
	111-130	4200K
	131-150	4500K
	151-170	5600K
	171-190	6000K
	191-210	6500K
	211-230	7200K
231-255	8000K	
6		Strobe
	0-9	No Function
	10-99	Strobe (Slow to fast)
	100-109	No Function
	110-179	Lightning Strobe
	180-189	No Function
190-255	Random Strobe	
7	0-255	Zoom
8		Zoom Reset
	0-200	No Function
	201-220	Zoom Reset
	221-255	No Function
9		Dimmer Speed
	0-9	No Function
	10-29	Off
	30-69	Dim1
	70-129	Dim2
	130-189	Dim3
190-255	Dim4	

# EXPOLITE

SSP		
1	0-255	Master Dimmer
2	0-255	Red
3	0-255	Green
4	0-255	Blue
5	0-255	White
6		Strobe
	0-9	No Function
	10-99	Strobe (Slow to fast)
	100-109	No Function
	110-179	Lightning Strobe
	180-189	No Function
	190-255	Random Strobe
7	0-255	Zoom
8		Zoom Reset
	0-200	No Function
	201-220	Zoom Reset
	221-255	No Function
9		Dimmer Speed
	0-9	No Function
	10-29	Off
	30-69	Dim1
	70-129	Dim2
	130-189	Dim3
	190-255	Dim4

# EXPOLITE

TOUR		
1	0-255	Master Dimmer
2	0-255	Red
3	0-255	Green
4	0-255	Blue
5	0-255	White
6		Colour Macro & White
	0-10	No Function
	11-30	Red 100% / Green Up / Blue 0%
	31-50	Red Down / Green 100% / Blue 0%
	51-70	Red 0% / Green 100% / Blue Up
	71-90	Red 0% / Green Down / Blue 100%
	91-110	Red Up / Green 0% / Blue 100%
	111-130	Red 100% / Green 0% / Blue Down
	131-150	Red 100% / Green Up / Blue Up
	151-170	Red Down / Green Down / Blue 100%
	171-195	All Led at Full Output
	196-200	2700K
	201-205	3000K
	206-210	3200K
	211-215	3500K
	216-220	4000K
	221-225	4200K
	226-230	4500K
	231-235	5600K
	236-240	6000K
241-245	6500K	
246-250	7200K	
251-255	8000K	
7		Strobe
	0-9	No Function
	10-99	Strobe (Slow to fast)
	100-109	No Function
	110-179	Lightning Strobe
	180-189	No Function
	190-255	Random Strobe



# EXPOLITE

8		Auto
	0 - 40	No Function
	41-50	Auto 1
	51-60	Auto 2
	61-70	Auto 3
	71-80	Auto 4
	81-90	Auto 5
	91-100	Auto 6
	101-110	Auto 7
	111-120	Auto 8
	121-130	Auto 9
	131-140	Auto 10
	141-150	Program 1
	151-160	Program 2
	161-170	Program 3
	171-180	Program 4
	181-190	Program 5
	191-200	Program 6
201-210	Program 7	
211-220	Program 8	
221-230	Program 9	
231-255	Program 10	
9	0-255	Auto Speed Adjustment
10	0-255	Zoom
11		Zoom Reset
	0-200	No Function
	201-220	Zoom Reset
	221-255	No Function
12		Dimmer Speed
	0-9	No Function
	10-29	Off
	30-69	Dim1
	70-129	Dim2
	130-189	Dim3
190-255	Dim4	

# EXPOLITE

## TR16

1	0-255	Master Dimmer
2	0-255	Master Dimmer Fine
3	0-255	Red
4	0-255	Red Fine
5	0-255	Green
6	0-255	Green Fine
7	0-255	Blue
8	0-255	Blue Fine
9	0-255	White
10	0-255	White Fine
11		Colour Macro & White
	0-10	No Function
	11-30	Red 100% / Green Up / Blue 0%
	31-50	Red Down / Green 100% / Blue 0%
	51-70	Red 0% / Green 100% / Blue Up
	71-90	Red 0% / Green Down / Blue 100%
	91-110	Red Up / Green 0% / Blue 100%
	111-130	Red 100% / Green 0% / Blue Down
	131-150	Red 100% / Green Up / Blue Up
	151-170	Red Down / Green Down / Blue 100%
	171-195	All Led at Full Output
	196-200	2700K
	201-205	3000K
	206-210	3200K
	211-215	3500K
	216-220	4000K
	221-225	4200K
226-230	4500K	
231-235	5600K	
236-240	6000K	
241-245	6500K	
246-250	7200K	
251-255	8000K	
12		Strobe
	0-9	No Function
	10-99	Strobe (Slow to fast)
	100-109	No Function
	110-179	Lightning Strobe
	180-189	No Function
	190-255	Random Strobe

# EXPOLITE

13		Auto
	0 - 40	No Function
	41-50	Auto 1
	51-60	Auto 2
	61-70	Auto 3
	71-80	Auto 4
	81-90	Auto 5
	91-100	Auto 6
	101-110	Auto 7
	111-120	Auto 8
	121-130	Auto 9
	131-140	Auto 10
	141-150	Program 1
	151-160	Program 2
	161-170	Program 3
	171-180	Program 4
	181-190	Program 5
191-200	Program 6	
201-210	Program 7	
211-220	Program 8	
221-230	Program 9	
231-255	Program 10	
14	0-255	Auto Speed Adjustment
15	0-255	Zoom
16		Zoom Reset
	0-200	No Function
	201-220	Zoom Reset
	221-255	No Function
17		Dimmer Speed
	0-9	No Function
	10-29	Off
	30-69	Dim1
	70-129	Dim2
	130-189	Dim3
190-255	Dim4	



## Delivery

- Expolite Tour-LED MC 60
- Power connection cable
- General Information for Expolite Units
- User Manual

Expolite devices are carefully checked before shipment. If the delivery is not complete, please contact your distributor immediately.

## Product Information

Voltage	100V - 240V AC 50/60Hz
Power Consumption	85W
Dimensions	348 x 176 x 242mm
Weight	5,4kg
Connectors	Power In/Out   DMX In/Out
Ambient Temperature	-20°C - 45°C
Humidity*	< 80%
Protection	IP 65
Housing	Die Cast Aluminium Housing
LEDs	1x 60W RGBW**
LED Current	4,5A
Optics	4,5° - 45°
Control	Stand-Alone / DMX512
DMX-Channels	9 - 17 (9/9/12/17)

\* take note to General Informations for Expolite Units - Notes for Condensation inside Housing.

\*\* Tolerance in colour temperature according to LED manufacturer +/- 10%.

### ILLUMINANCE AT DISTANCE

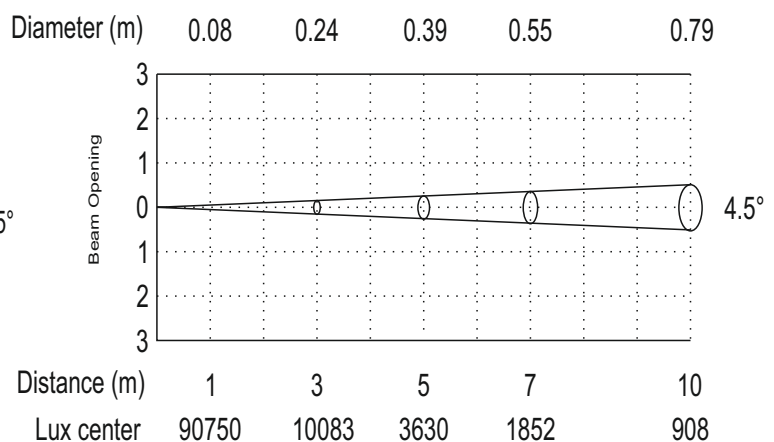
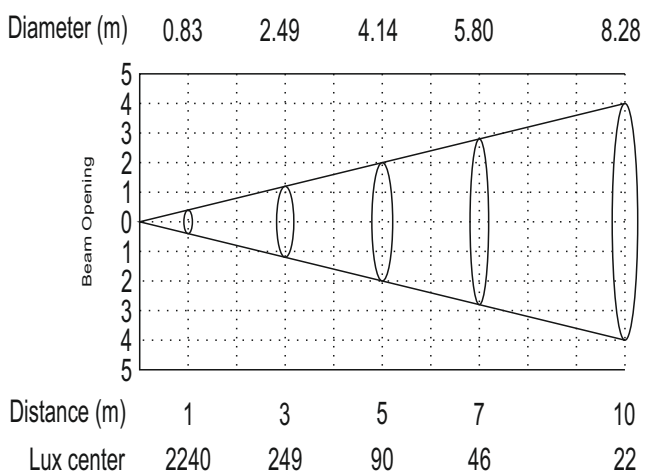

## Dimensions

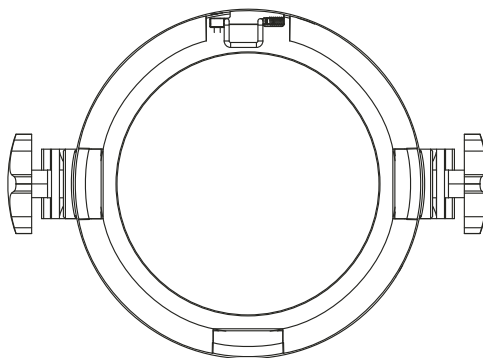
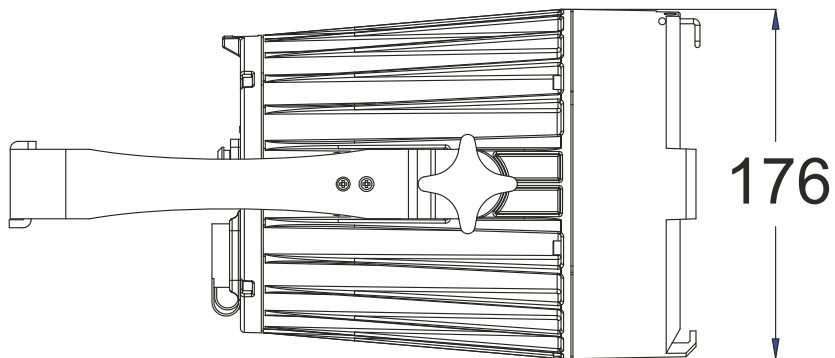
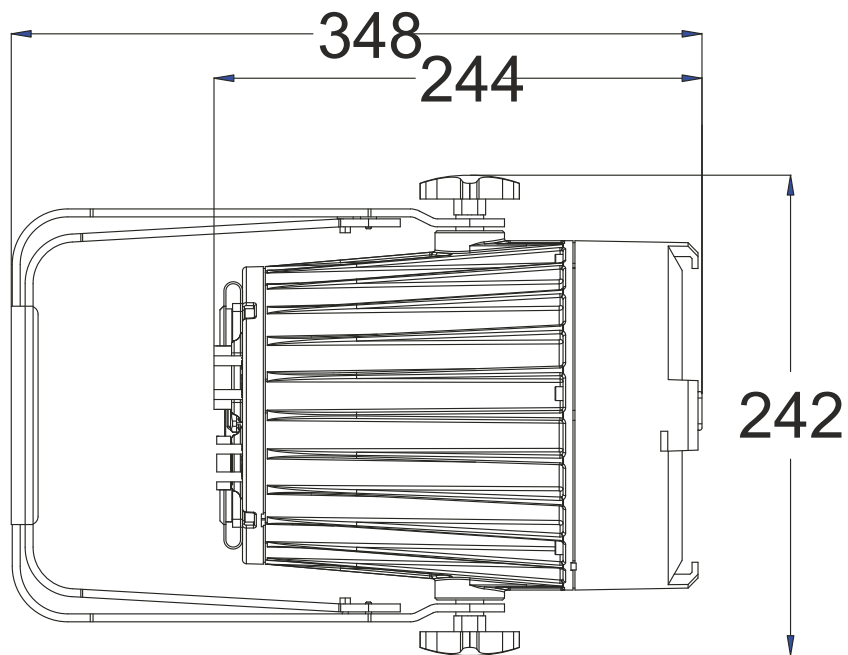

## Installation

### Mounting

### Hanging

The device can be used in any position. On the mounting bracket are holes available, for attaching standard brackets. Fixture must be safe mounted in accordance with the relevant regulations and provided with a safety cord to prevent falling. For this purpose, an eyelet for safeties is attached to the device.

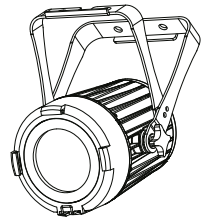

### Standing

The device can be placed directly on the mounted bracket. For this purpose, it must be opened up to the mechanical stop.

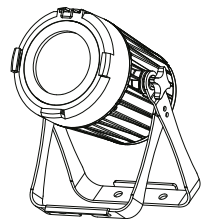

### NOTE

The LED module can be operated in any position.

### Powerconnection

230V: max. 20 fixtures in a row.

120V: max 10 fixtures in a row.

### DMX-Connection

Use specified DMX-cables to connect the units to each other and to connect them to the control-desk. Enter the addresses and personalities to the units.

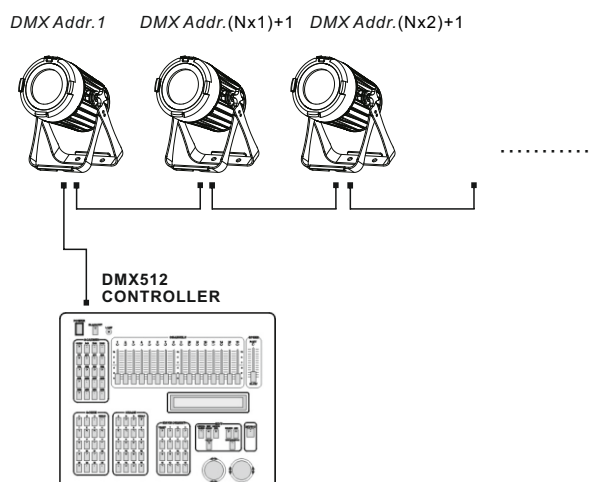

## Operation

### Display Operation

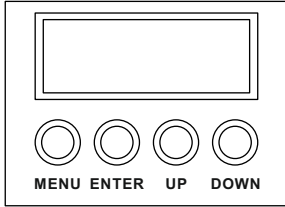

MENU:  
ENTER:  
UP:  
DOWN:

Return to previous menu  
Enter currently selected menu  
Scroll Up, Increase value  
Scroll down: Decrease value

### Menu Map

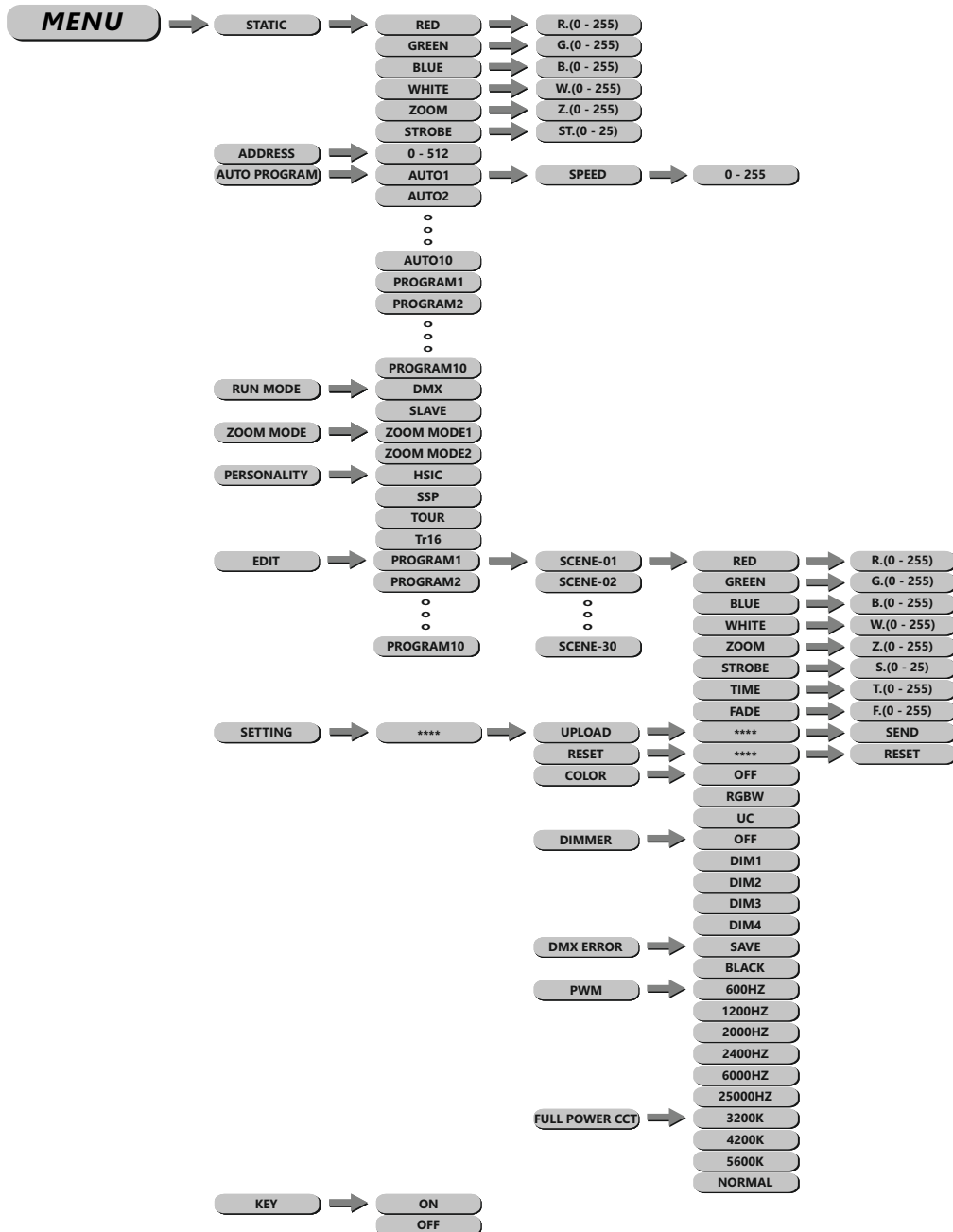



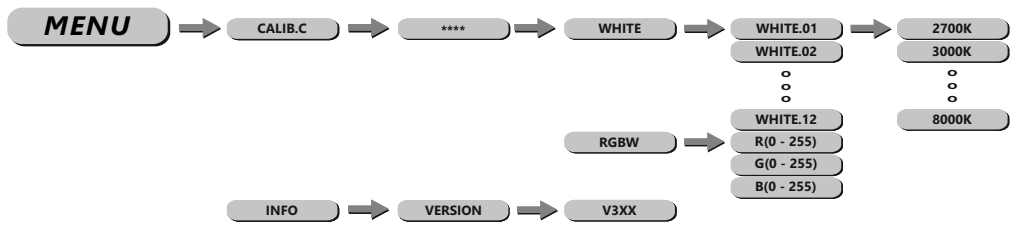

## Setting DMX-Address



The DMX start address of the fixture is set in the menu **ADDRESS**. This is retained even when changing the personality.

## Setting DMX-Personality



The personality is set in the menu **PERSONALITY**. There are four different modes which can be chosen: **HSIC** (9 channels), **SSP** (9 channels), **TOUR** (12 channels) and **TR16** (17 channels).

## Edit Static Colours

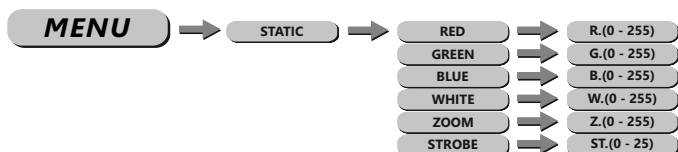

Static colours for stand-alone operation are set in **STATIC**. These are mixed using the DMX value scale 0-255 for **RED**, **GREEN**, **BLUE**, **WHITE** and **ZOOM**, as well as the **STROBE** value 0-25Hz.

## Activating Auto Programs

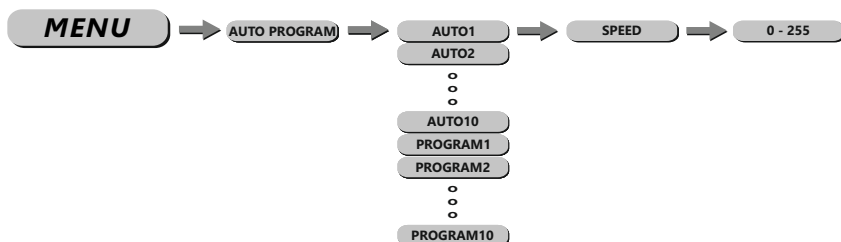

In the menu **AUTO PROGRAM** the automatic programs stored in the device are activated. The programs **AUTO1** to **AUTO10** are permanently stored in the device. The programs **PROGRAM1** to **PROGRAM10** are editable. This is described under **Edit User Programs**. Automatic programs are transmitted as master to connected slave devices. For master-slave operation, signals are sent via the DMX line. This may disturb other devices on the same line.

# EXPOLITE

## Zoommode auswählen



In the **ZOOM MODE** menu the speed of the motorised zoom is set. In **ZOOM MODE1** the Zoom runs at maximum speed, in **ZOOM MODE2** it runs slower but with less loudness.

## Choose Run Mode



The operating mode is set in menu **RUN MODE**. For operation on a DMX-controller **DMX** needs to be set. **SLAVE** sets the fixture into slave mode.

## Edit User Programs

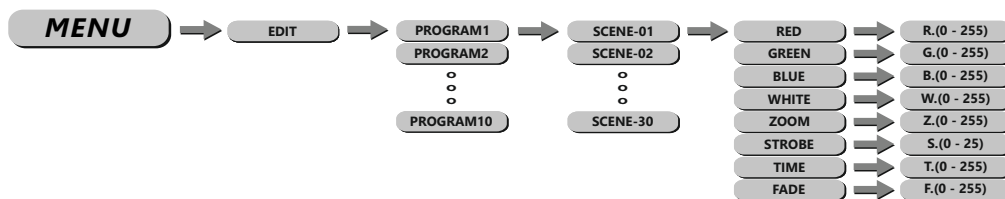

In the menu **EDIT** the user programs **PROGRAM1** to **PROGRAM10** can be edited. Every program can have up to 30 steps (**SCENE-01** - **SCENE-30**). Every step persists of the parameter colours **RGBW**, **ZOOM**, **STROBE** „0-20Hz“, **TIME** and **FADE**. User programs can be transferred to other fixtures (see master/slave).

Step-by-step programming of the custom stand-alone programs with up to 30 different steps.

**NOTE:** For less than 30 steps the **TIME** and **FADE** of the last step needs to be set to 0.

Example for time settings of a stand-alone programm with 3 steps:

Step 1 **TIME** = 4    **FADE** = 3  
Step 2 **TIME** = 5    **FADE** = 2  
Step 3 **TIME** = 0    **FADE** = 0

## Miscellaneous Settings

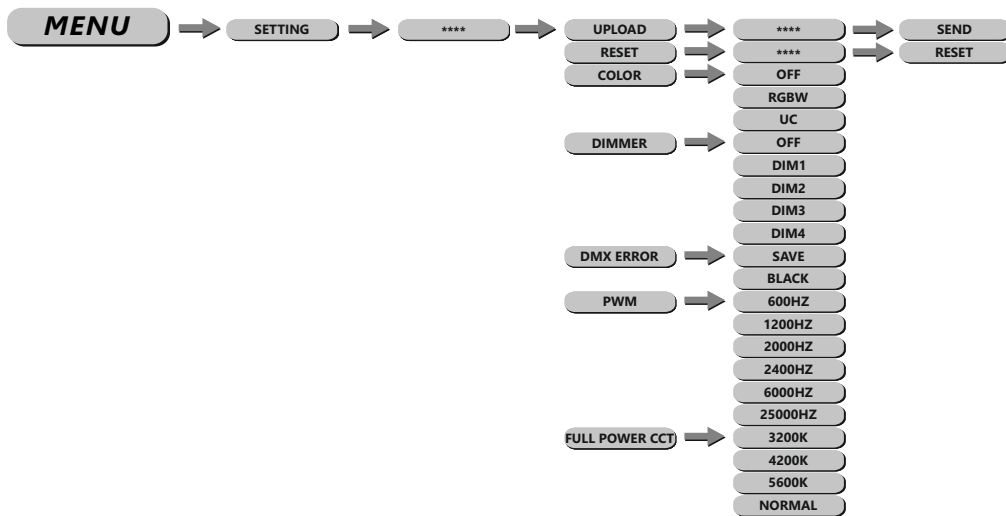

The default password is: **UP - DOWN - UP - DOWN - ENTER**

**UPLOAD:** sends the user programs to connected slave fixtures.

**RESET:** sets all editable settings back to factory default.

**COLOR:** in this submenu a colour calibration is selected or deactivated. When **RGBW** is selected, the maximum brightness values at DMX = 255 are limited to the values set in **CALIB.C\RGBW**. When **UC** is selected the Uniform-Colour factory calibration is used, which adjusts devices of different generations. If the value is set **OFF**, the calibration is deactivated and the device reaches the maximum brightness.

**DIMMER:** controls different dimming speeds to simulate a halogen bulb (**OFF/DIM1/DIM2/DIM3/DIM4**).

**DMX ERROR:** sets how the fixture responds if DMX-signal gets lost. Set **SAVE** to hold the last received value or **BLACK** for blackout.

**PWM:** gives the user the possibility to adjust the PWM frequency of the leds (**600Hz/1200Hz/2000Hz/2400Hz/6000Hz/25000Hz**).

**FULL POWER CCT:** sets the colour temperature at maximum output. **3200K/4200K/5600K/** and **NORMAL** can be set.

## Activate Password Protection



In the menu **KEY** the password protection of the fixture is activated or deactivated. If set **ON** the fixture is password protected when started. 30 seconds after the last setting the menu is locked again. To be able to make changes in the menu the password **UP - DOWN - UP - DOWN - ENTER** needs to be typed in.

## Calibration and Whiteadjustment

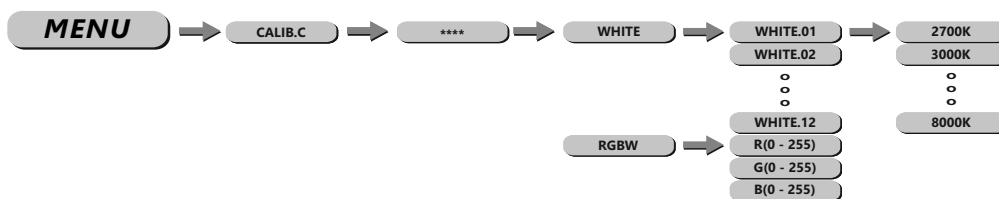

In the menu **CALIB.C** the calibrations and whiteadjustments can be set.

In the submenu **WHITE** the preset colour temperatures for the white values are stored.

In the menu **RGBW** a custom colour calibration is stored which limits the maximum brightness of the colour channels at the DMX value "255".

**NOTE:** The maximum value can be limited to 0. In this case, a colour channel does not respond to a sent DMX value, which can be misinterpreted as a device error.

## Info Menu



In the info menu (**INFO**), submenu **VERSION** the currently installed firmware version is shown. In the submenu **RDM**, submenu **UID** the RMD-ID of the fixture and in the submenu **LABEL** the model name of the fixture can be found.



# Using DMX512 Control

## DMX-Channel assignment

This device has several DMX personalities. In each personality a different number of DMX channels is used and the reaction of the device differs accordingly. There are four DMX personalities with 9, 9, 12 and 17 channels selectable.

Because of changes in the firmware of the fixture, functions can be added or changed. You can find the current version „DMX-Channels“ as PDF-file on the website, ready to download.

HSIC		
1	0-255	Intensity
2	0-255	Hue
3	0-255	Hue Fine
4	0-255	Saturation
5		CCT
	0-10	No Function
	11-30	2700K
	31-50	3000K
	51-70	3200K
	71-90	3500K
	91-110	4000K
	111-130	4200K
	131-150	4500K
	151-170	5600K
	171-190	6000K
	191-210	6500K
	211-230	7200K
231-255	8000K	
6		Strobe
	0-9	No Function
	10-99	Strobe (Slow to fast)
	100-109	No Function
	110-179	Lightning Strobe
	180-189	No Function
190-255	Random Strobe	
7	0-255	Zoom
8		Zoom Reset
	0-200	No Function
	201-220	Zoom Reset
	221-255	No Function
9		Dimmer Speed
	0-9	No Function
	10-29	Off
	30-69	Dim1
	70-129	Dim2
	130-189	Dim3
190-255	Dim4	

# EXPOLITE

SSP		
1	0-255	Master Dimmer
2	0-255	Red
3	0-255	Green
4	0-255	Blue
5	0-255	White
6		Strobe
	0-9	No Function
	10-99	Strobe (Slow to fast)
	100-109	No Function
	110-179	Lightning Strobe
	180-189	No Function
	190-255	Random Strobe
7	0-255	Zoom
8		Zoom Reset
	0-200	No Function
	201-220	Zoom Reset
	221-255	No Function
9		Dimmer Speed
	0-9	No Function
	10-29	Off
	30-69	Dim1
	70-129	Dim2
	130-189	Dim3
	190-255	Dim4

# EXPOLITE

TOUR		
1	0-255	Master Dimmer
2	0-255	Red
3	0-255	Green
4	0-255	Blue
5	0-255	White
6		Colour Macro & White
	0-10	No Function
	11-30	Red 100% / Green Up / Blue 0%
	31-50	Red Down / Green 100% / Blue 0%
	51-70	Red 0% / Green 100% / Blue Up
	71-90	Red 0% / Green Down / Blue 100%
	91-110	Red Up / Green 0% / Blue 100%
	111-130	Red 100% / Green 0% / Blue Down
	131-150	Red 100% / Green Up / Blue Up
	151-170	Red Down / Green Down / Blue 100%
	171-195	All Led at Full Output
	196-200	2700K
	201-205	3000K
	206-210	3200K
	211-215	3500K
	216-220	4000K
	221-225	4200K
	226-230	4500K
	231-235	5600K
	236-240	6000K
241-245	6500K	
246-250	7200K	
251-255	8000K	
7		Strobe
	0-9	No Function
	10-99	Strobe (Slow to fast)
	100-109	No Function
	110-179	Lightning Strobe
	180-189	No Function
	190-255	Random Strobe



# EXPOLITE

8		Auto
	0 - 40	No Function
	41-50	Auto 1
	51-60	Auto 2
	61-70	Auto 3
	71-80	Auto 4
	81-90	Auto 5
	91-100	Auto 6
	101-110	Auto 7
	111-120	Auto 8
	121-130	Auto 9
	131-140	Auto 10
	141-150	Program 1
	151-160	Program 2
	161-170	Program 3
	171-180	Program 4
	181-190	Program 5
	191-200	Program 6
201-210	Program 7	
211-220	Program 8	
221-230	Program 9	
231-255	Program 10	
9	0-255	Auto Speed Adjustment
10	0-255	Zoom
11		Zoom Reset
	0-200	No Function
	201-220	Zoom Reset
	221-255	No Function
12		Dimmer Speed
	0-9	No Function
	10-29	Off
	30-69	Dim1
	70-129	Dim2
	130-189	Dim3
190-255	Dim4	

# EXPOLITE

## TR16

1	0-255	Master Dimmer
2	0-255	Master Dimmer Fine
3	0-255	Red
4	0-255	Red Fine
5	0-255	Green
6	0-255	Green Fine
7	0-255	Blue
8	0-255	Blue Fine
9	0-255	White
10	0-255	White Fine
11		Colour Macro & White
	0-10	No Function
	11-30	Red 100% / Green Up / Blue 0%
	31-50	Red Down / Green 100% / Blue 0%
	51-70	Red 0% / Green 100% / Blue Up
	71-90	Red 0% / Green Down / Blue 100%
	91-110	Red Up / Green 0% / Blue 100%
	111-130	Red 100% / Green 0% / Blue Down
	131-150	Red 100% / Green Up / Blue Up
	151-170	Red Down / Green Down / Blue 100%
	171-195	All Led at Full Output
	196-200	2700K
	201-205	3000K
	206-210	3200K
	211-215	3500K
	216-220	4000K
	221-225	4200K
226-230	4500K	
231-235	5600K	
236-240	6000K	
241-245	6500K	
246-250	7200K	
251-255	8000K	
12		Strobe
	0-9	No Function
	10-99	Strobe (Slow to fast)
	100-109	No Function
	110-179	Lightning Strobe
	180-189	No Function
	190-255	Random Strobe

# EXPOLITE

13		Auto
	0 - 40	No Function
	41-50	Auto 1
	51-60	Auto 2
	61-70	Auto 3
	71-80	Auto 4
	81-90	Auto 5
	91-100	Auto 6
	101-110	Auto 7
	111-120	Auto 8
	121-130	Auto 9
	131-140	Auto 10
	141-150	Program 1
	151-160	Program 2
	161-170	Program 3
	171-180	Program 4
	181-190	Program 5
	191-200	Program 6
201-210	Program 7	
211-220	Program 8	
221-230	Program 9	
231-255	Program 10	
14	0-255	Auto Speed Adjustment
15	0-255	Zoom
16		Zoom Reset
	0-200	No Function
	201-220	Zoom Reset
	221-255	No Function
17		Dimmer Speed
	0-9	No Function
	10-29	Off
	30-69	Dim1
	70-129	Dim2
	130-189	Dim3
190-255	Dim4	

**EXPOLITE**

**CE RoHS**