

XND-4
4-Port Ethernet DMX Node
User Manual

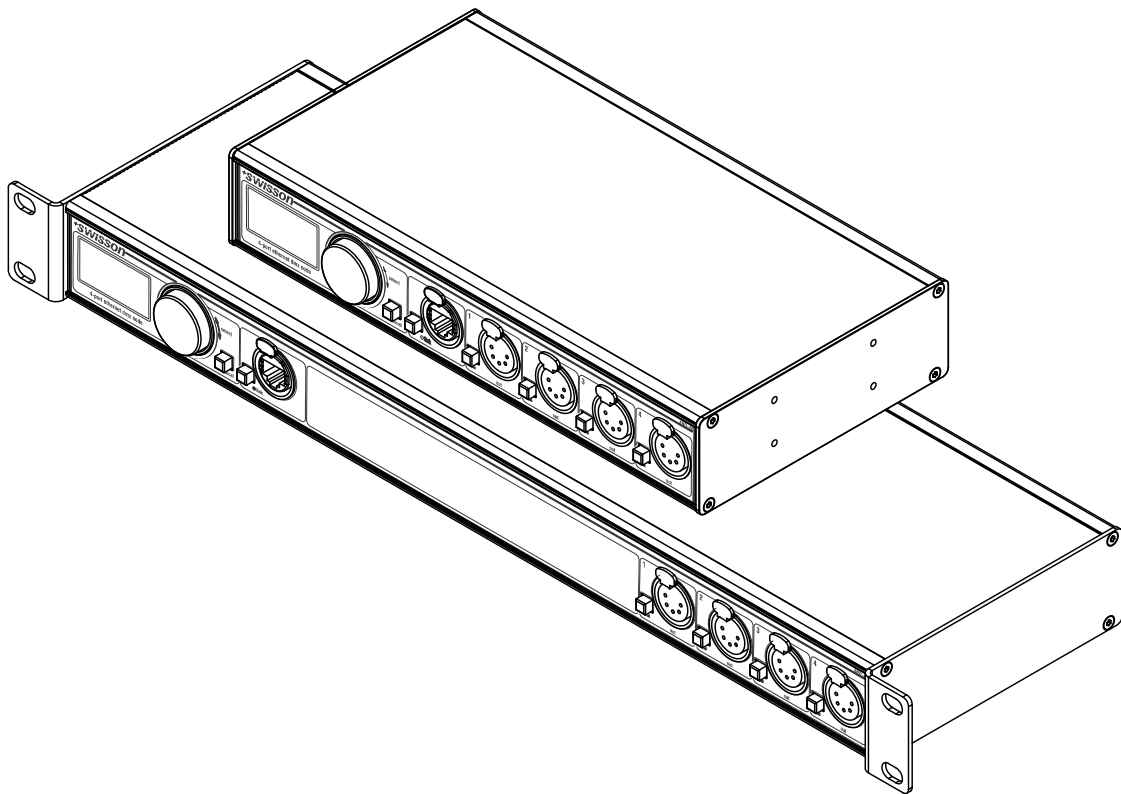

Index

Index.....	3
Introduction	4
Unpacking	4
Safety Information	5
Device Overview	7
Settings and Menu	9
Ethernet Port Status Information	19
Status LEDs.....	19
Screen Saver.....	20
Firmware Updates.....	20
Technical Data.....	21
Ordering Information	22
Credits	22
Appendix	23

Introduction

XND-4 is a user-friendly Art-Net and sACN to DMX converter supporting the distribution of four universes of DMX via four individually optically isolated DMX outputs. Since most major lighting consoles are capable of transmitting Art-Net data, XND-4 is all you need to take advantage of your console's networking capability, allowing you to transmit a vast number of universes over one single network cable. In some cases, users may profit from already existing networking infrastructure.

Further, the XND-4 is also perfectly suited to send DMX data to your fixtures from a computer or even from a mobile device. Many light controller programs for PC or Mac support Art-Net output natively and with the help of XND-4's DHCP capability, you can even let your workplace network infrastructure do the network configuration of your XND-4 automatically for you.

With its 128x64 pixels OLED display however, configuring the network and setting up your Art-Net or sACN preferences manually is no trouble at all and helpful status information is always at hand.

Applications

- Concert lighting
- Live events
- Multimedia shows
- Theaters
- TV studios
- Theme parks
- Architectural lighting

Typical Application

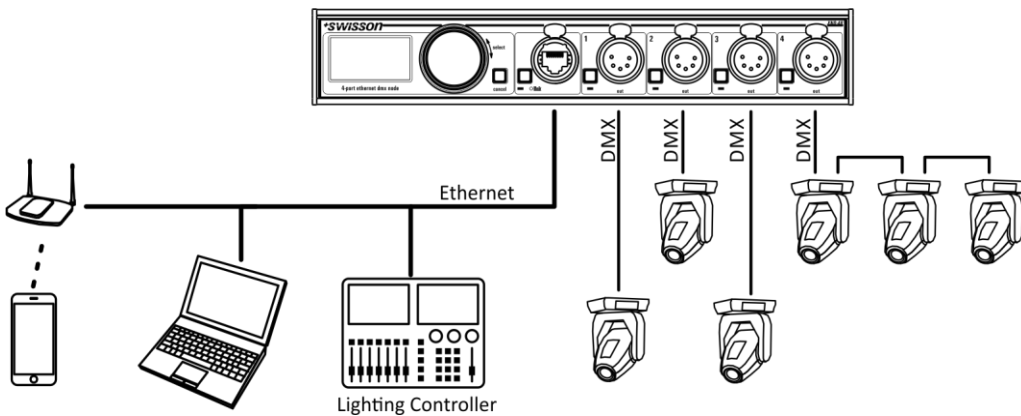

Unpacking

The XND-4 is packaged in a cardboard box. The following items are included:

- The device.
- This user manual.

Safety Information

It is essential that you read and understand this manual before operating the device and that you follow the instructions given below closely when you set up, connect and use the XND-4. Do not use the device in any way or for any purpose not described in this user manual.

This product is approved for professional use only; it is not intended for household usage. Pay attention to all warnings given in this manual and use this device only in accordance with applicable laws and regulations.

Safety Precautions

- **Disconnect the device from the AC power supply before removing any cover or part, including fuses, even when not in use.**
- **Ensure that the device is electrically connected to ground (earth).**
- **Use only a source of AC power supply that complies with local building and electrical regulations and which has both overload and ground-fault (earth fault) protection.**
- **Before using the device, check that the power distribution equipment and cables are in perfect condition and rated for the current required by all connected devices.**
- **Isolate the device from power supply immediately if the power cable or the power plugs are in any way damaged, defective or wet, or if they show signs of overheating.**
- **Do not expose the device to rain or moisture.**
- **Do not operate the device if any cover or component is missing, damaged or deformed.**
- **Refer any service operation not described in this manual to Swisson.**
- **Provide unrestricted airflow around the device.**
- **Do not operate the device if the ambient temperature exceeds 55°C (131°F).**
- **Do not modify the device in any way not described in this manual or install other than genuine Swisson parts.**
- **Do not attempt to bypass any fuse. Replace any defective fuse with one of the specified type and rating only.**
- **When suspending the device, ensure that the supporting structure and all hardware used can hold at least 10 times the weight of all devices suspended together.**
- **When suspending the device, install a secondary attachment such as a safety cable that is approved by an official body such as, e.g. TÜV (German Technical Monitoring Association), a safety attachment for the total weight it secures. The safety cable must comply with EN 60598-2-17 section 17.6.6 and be capable of bearing a static suspended load 10 times the weight of the device.**
- **Make sure that any external cover and rigging hardware is securely fastened.**
- **Provide an adequate clearance underneath the work area and a stable platform whenever installing, servicing or moving an overhead device.**

- Do not use the device in areas where it is exposed to direct sunlight.
- Do not use the device in areas that are “highly inflammable”.

Device Overview

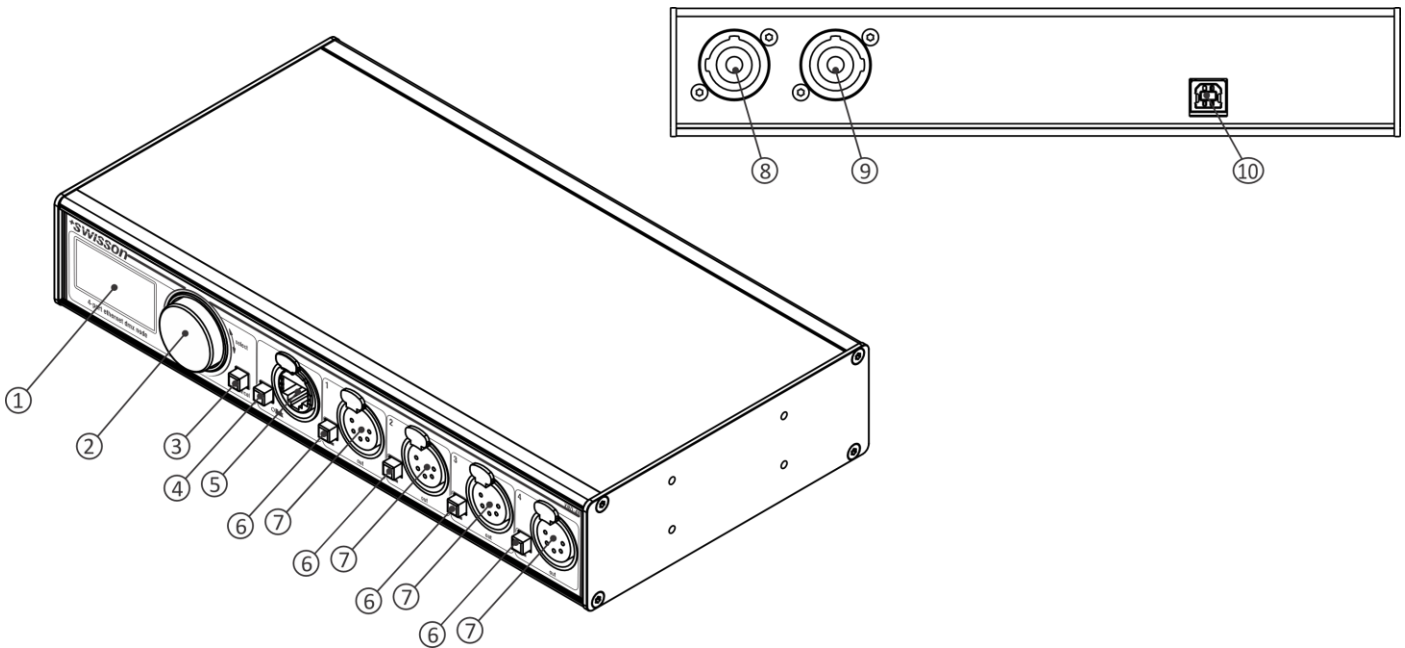

1. OLED display.
2. Encoder wheel / [OK] button. The encoder is primarily used for selecting menu items by turning the knob. It also functions as a push button. This manual refers to this button simply as [OK] button or [OK].
3. [Cancel] button.
4. Ethernet port button [E].
5. Ethernet port (RJ45 Neutrik etherCON socket).
6. Output port buttons [1] – [4]. These push buttons are used to change to which universe the respective output is connected. An output port status LED showing status information is located directly below each of those buttons.
7. Signal output ports 1 – 4.
8. Neutrik powerCON input socket.
9. Neutrik powerCON output socket.
10. USB type-B socket for firmware updates.

Mains Connection

The user must supply a suitable power cable. He may then either hard-wire the power cable to the building's electrical installation, providing an easily accessible power on/off switch close to the device, or install on the power cable a grounding-type (earthed) mains plug that is suitable for the local power outlets, following the power plug manufacturer's instructions. Consult a qualified electrician, if you have any doubts about the proper installation.

A blue *Neutrik powerCON NAC3FCA* cable mount connector must be used to supply power at the XND-4's power input socket.

Warning! For protection against dangerous electrical shocks, the device must be grounded (earthed). The local AC power source must be supplied with both overload and ground-fault (earth fault) protection.

Important! Only attach or remove a Neutrik powerCON connector while it is connected to the mains to apply or cut power in an emergency, as by doing so may cause arcing at the terminals that will damage the connectors.

Power Outlet

Warning! The total current load of all devices connected to the AC mains power outlet of the XND-4 must not exceed 19.8 amperes.

- A power cable that meets the requirements specified in the safety instructions section of this manual must be used to connect the XND-4 to AC mains power and to connect other devices to the power outlet.
- A light-grey Neutrik powerCON NAC3FCB cable-mount connector must be used to draw AC mains power from the XND-4's power outlet.
- No matter what the AC mains power voltage is, the current drawn by all the devices that draw AC mains power from the power outlet of an XND-4 must not exceed a total of 19.8 amperes.

DMX Connections

Depending on the version, the XND-4 is equipped with 5-pin or 3-pin XLR connectors or with Neutrik etherCON RJ45 connectors.

XLR Connectors

Pin	Connection
1	Com
2	Data -
3	Data +
4	Not connected
5	Not connected

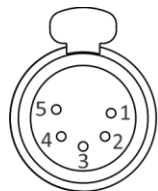

5-Pin XLR female
(DMX out)

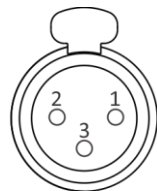

3-Pin XLR female
(DMX out)

RJ45 Connectors

Pin	Connection
1	Data +
2	Data -
3	Not connected
4	Not connected
5	Not connected
6	Not connected
7	Com
8	Com
Shield	Earth

Each output port is individually optically isolated.

Settings and Menu

General Navigation

The encoder wheel (see page 7) is the primary means for navigating through the menus. Most of the menus arrange items vertically. In those menus, turn the encoder clockwise to select the item below the currently selected item or turn the encoder counter clockwise to select the item above the currently selected item. In menus that arrange items horizontally (e.g. text fields), clockwise means “to the right” and counter clockwise means “to the left”.

Other than that, the encoder wheel also functions as a push button. This button is generally used to confirm a selection or to navigate to a selected submenu. This manual will also refer to pushing the encoder knob as “push [OK]” or “push the [OK] button”.

On the right side of the encoder knob, you can find the [Cancel] button (depicted on page 7), which is generally used to dismiss a selection or to exit a menu.

By keeping the [Cancel] button pressed for at least two seconds, you can always navigate to the Home Screen. From the Home Screen, the menu is launched by simply pushing the [OK] button.

The following notation is used to describe locations in the menu: *Home > Menu > Sub menu > ...*

For example, the manual could say “navigate to *Home > Menu > Art-Net*”. This can be read as follows:

Keep [Cancel] pressed for 2 seconds to reach the Home Screen.

XND-4			
IP Address		2.169.1.23	
Net	14h	Sub-Net	Bh
ART-NET	ART-NET	-	sACN
0h	1h	Off	Ah

Then, press [OK] to get to the menu.

MENU	
Network	
Art-Net	
Outputs	
Device Settings	
Restore Default Settings	

Select *Art-Net* using the encoder wheel.

MENU	
Network	
Art-Net	
Outputs	
Device Settings	
Restore Default Settings	

After pressing [OK] again to confirm the selection, the Art-Net settings menu is displayed.

ART-NET SETTINGS	
Net	
Sub-Net	
Name	
Short Name	

Home Screen

XND-4			
IP Address		192.168.10.125	
Net		0 Sub-Net 0	
ART-NET	sACN	-	sACN
10	8192	Off	1

Home Screen of an XND-4 configured to a custom IP address (192.168.10.125) with Art-Net and sACN universe addressing information displayed in decimal.

XND-4			
IP Address		2.169.1.23	
Net		0Ah Sub-Net Bh	
ART-NET	ART-NET	ART-NET	sACN
0h	1h	2h	Ah

Home Screen of an XND-4 configured to its default Art-Net IP address with Art-Net and sACN universe addressing information displayed in hexadecimal.

XND-4			
IP Address		10.169.0.18	
Net		14h Sub-Net Ah	
Art-Net Universes			
0h	1h	Off	Fh

Home Screen of an XND-4 configured to its alternative Art-Net IP address with Art-Net and sACN universe addressing information displayed in hexadecimal.

The Home Screen shows the IP address of the node and by default also the current Art-Net net and the Art-Net sub-net of the node. The numbers at the bottom of the screen display the 4-bit Art-Net universe of each each output port running in Art-Net mode if independent Art-Net universes are disabled (see Independent Universes on page 11).

If independent Art-Net universes are enabled, Art-Net net and Art-Net sub-net are not displayed and the numbers at the bottom of the screen that correspond to a port running in Art-Net mode are values in the range of 0 to 32767. This number fully identifies a port's universe and is also referred to as the port address. For more information on the addressing of Art-Net ports, see section Representations of Art-Net Port Addresses in the Appendix.

For each port running in sACN mode, the 16-bit sACN universe is displayed at the bottom of the screen. The left most number corresponds to the universe of output 1.

Network Settings

The network settings can be found under *Home > Menu > Network*.

DHCP

Navigate to *Home > Menu > Network > DHCP* in order to enable or disable DHCP (Dynamic Host Configuration Protocol). Choose *Enable* if you want to have your network configured by a DHCP server. This would typically be the case if you connect the XND-4 to a home or office network.

A bullet point is shown next to the currently active setting. Use the encoder wheel to choose the desired setting and confirm by pressing [OK] in order to change the setting.

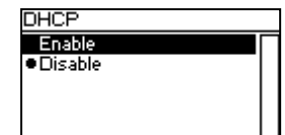

Static Settings

All settings under *Home > Menu > Network > Static Settings* apply only if DHCP is disabled and are ignored otherwise. From this menu, you can choose the IP address, the netmask and the gateway address to be used when DHCP is disabled.

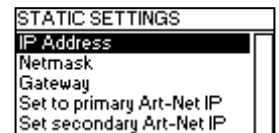

IP Address

Use this menu item to configure the device's IP address. When the IP address configuration dialog is opened, it will look just like the dialog depicted to the right. A box encircling the first number indicates that the first number is selected. While the first number (byte) of the IP address is selected, use the encoder wheel in order to choose the desired value for the first byte of the address, then push [OK] to confirm your selection.

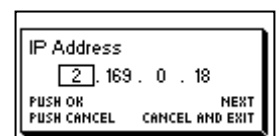

The next number will become selected allowing you to configure the second number. Simply repeat the same steps for the remaining numbers. After confirming the value of the last byte, the dialog will be closed, and the new settings will be applied.

Netmask

In order to configure the netmask, use the same procedure as for configuring the IP address.

The netmask is used internally to compute the network address from the IP address. XND-4 does this by computing the bitwise AND of each byte with the corresponding byte of the IP address. The bitwise AND of the first byte of the IP address and the first byte of the netmask is the first byte of the network address and so on.



Gateway

In order to configure the default gateway address, use the same procedure as for configuring the IP address or the netmask. If the network data sent by the node needs to be routed, you may want to set this address to the address of your router. In most cases, however, this setting is not relevant.

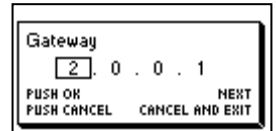

Set to Primary Art-Net IP

After navigating to the menu item *Home > Menu > Network > Static Settings > Set to primary Art-Net IP*, a dialog as shown on the right will appear. Press [Cancel] to abort or press [OK] in order to apply the following settings:

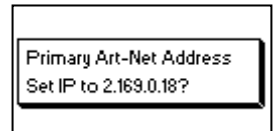

... *Static Settings > IP Address* is set to the primary Art-Net IP address (2.X.Y.Z). The values X, Y and Z are computed from the device's MAC address.

... *Static Settings > Netmask* is set to 255.0.0.0.

Set to Secondary Art-Net IP

As *Set to Primary Art-Net IP*, but sets network settings to the following values:

... *Static Settings > IP Address* is set to the secondary Art-Net IP address (10.X.Y.Z).

... *Static Settings > Netmask* is set to 255.0.0.0.

Art-Net Settings

Node-wide Art-Net settings can be configured under *Home > Menu > Art-Net*.

Net

To adjust the Art-Net net of the node, navigate to *Home > Menu > Art-Net > Net* and adjust the number using the encoder wheel. Once the desired number has been selected, push [OK] to apply the new setting or press [Cancel] to abort.

This part of the Art-Net address was introduced with Art-Net 3. In order to work with Art-Net I and Art-Net II controllers, Art-Net net needs to be set to 0.

Note that changing this setting while independent Art-Net universes are enabled still affects all Art-Net port addresses. For more information, see Independent Universes below.

Sub-Net

The Art-Net sub-net is configured under *Home > Menu > Art-Net > Sub-Net* in the same way net is configured.

Note that changing this setting while independent Art-Net universes are enabled still affects all Art-Net port addresses. For more information, see Independent Universes below.

Independent Universes

Independent Art-Net universes may be enabled and disabled under *Home > Menu > Art-Net > Independent Universes*. If independent Art-Net universes are enabled, the ports of the Art-Net node do not need to share the same Art-Net net and sub-net addresses.

When this feature is enabled, each output port has an independent port address in the range of 0 to 32767, which is computed from the Art-Net net, sub-net and universe number. This allows for configuring the node to any combination of Art-Net universes. However, if the Art-Net net or the Art-Net sub-net settings are changed (remotely or in the menu), each output port address is recomputed. For more information on the addressing of the Art-Net ports, see section Representations of Art-Net Port Addresses in the Appendix.

Unfortunately, due to restrictions of Art-Net, the node may no longer correctly report the port addresses of its outputs to a controller when this feature is enabled, which might confuse a controller and lead to problems. Therefore, it is recommended to avoid enabling independent universes whenever possible.

Name

The device name can be viewed and edited under *Home > Settings >*

Deleting Text

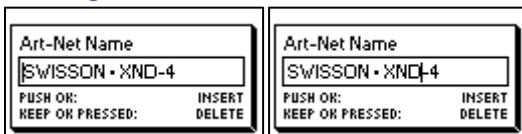

To delete a text line or a part of it, position the cursor immediately to the left of the first character you want to have deleted.

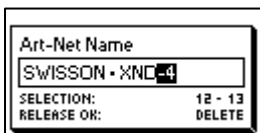

Then keep [OK] pressed and turn the encoder clockwise until all of the text that you wish to delete appears highlighted.

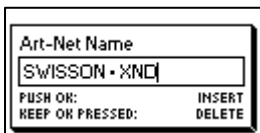

As you release the [OK] button, the highlighted text is removed.

Inserting or Appending Text

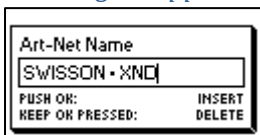

To append or insert text, move the cursor to the position where you want to add your text.

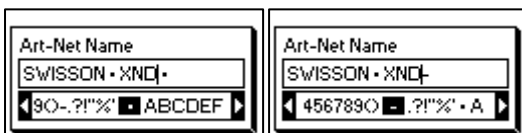

Then push the [OK] button and select a character to add.

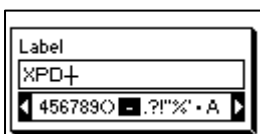

Confirm your selection by pressing [OK].

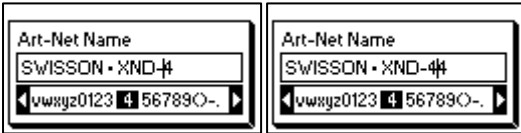

Repeat the above steps for the remaining characters. Then, press [Cancel] to finish inserting characters.

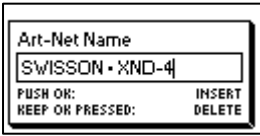

Press [Cancel] again to quit the editor.

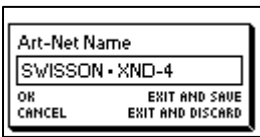

Press [OK] to store the changes or press [Cancel] to discard all changes.

Short Name

The short name can be viewed and edited under *Home > Menu > Art-Net > Short Name*. Editing the short name is done in the same way the name is edited.

Output Settings and Information

For each output port, there is an output port settings menu under *Home > Menu > Outputs > Output [1-4]*. E.g. the menu for output 1 is under *Home > Menu > Outputs > Output 1*. The output settings menu contains the items described below.



Mode

Under *Mode*, a selection list is presented to you with the following options:

- *Art-Net*: The port outputs data received via the Art-Net protocol.
- *sACN*: The port outputs data received via the sACN protocol.
- *Off*: The port is turned off.

A bullet point is shown next to the currently active setting. Use the encoder wheel to select the desired setting and push [OK] to apply the setting.

Merge Mode

Under *Merge Mode*, a selection list is presented to you with the following options:

- *HTP*: Highest takes precedence. If for a given DMX channel data has been received from two sources, the higher value is used.
- *LTP*: Latest takes precedence. If for a given DMX channel data has been received from two sources, LTP merging uses the value of whichever source was the last to change the value it has sent for that given channel.

Merging is applied when more than one Art-Net or sACN controller sends data for the same port. If more than two controllers send data for the same port, only two controllers are considered.

A bullet point is shown next to the currently active setting. Use the encoder wheel to select the desired setting and push [OK], to apply the setting.

Failure Behaviour

Under *Failure Behaviour*, a selection list is presented to you with the following options:

- *Off*: The output will stop sending DMX, after no updates for the universe of the output have been received for 6 seconds.
- *Hold Last Look*: The output will continue to send the last look even if no updates are received.

A bullet point is shown next to the currently active setting. Use the encoder wheel to select the desired setting and push [OK] to apply the setting.

Art-Net RDM

Under *Art-Net RDM*, RDM may be enabled or disabled for the output. RDM only works if the output port is running in Art-Net mode. XND-4 discovers a maximum of 250 devices per output port.

Universe

To adjust the universe of output port X, navigate to *Home > Menu > Outputs > Output X > Universe*. This screen can also be reached by pressing the corresponding output port button (button [1] – button [4], see page 7).

Output Port 1		Art-Net
Status	No DMX	UNIVERSE
Net	0	10
Sub-Net	0	
Sub-Uni	10	

This screen provides essential information about the DMX output and allows for changing its Art-Net or sACN universe.

Use the encoder wheel for changing the universe of the given output port. Once the desired universe appears on the screen, push OK to use this universe or press cancel to revert to the previously configured universe.

The screen looks slightly different whether the output port is in Art-Net or in sACN mode.

If no user input occurs while this screen is active for 20 seconds, the screen closes itself.

Art-Net Mode (Independent Universes Disabled)

This section describes the screen for editing the universe of an output port running in Art-Net mode when the independent universes feature is disabled. See Independent Universes on page 11 for details about the independent universes feature.

Please note that while the universe (large number on the right-hand side of the display) is being edited but has not yet been stored, its background lights up and the number is displayed in its inverted colour about once every second. If that is the case and you just want to see the configured universe number, simply press [Cancel].

On the left-hand side of the screen, the following information is displayed on four lines:

- The first line displays the output port status, which can be *No DMX*, *Off*, *Hold* or *DMX OK*:
 - *No DMX* means that the port is enabled, but no DMX is being sent.
 - *Off* means that the port is currently disabled.
 - *Hold* means that the port is currently sending a look which has been received before, but no updates have been received for at least 6 seconds.
 - *DMX OK* is to let you know, that the port is sending DMX data and recent updates have been received.
- The other lines display the Art-Net net, the Art-Net sub-net and the Art-Net sub-uni of the port.
The Art-Net sub-uni is computed from the sub-net and the universe of a port as $16 \times \text{sub-net} + \text{universe}$. Some controllers address the Art-Net universe as a single number in the range of 0 to 255. Sub-uni corresponds to that number.

Art-Net Mode (Independent Universes Enabled)

When independent universes are enabled, ports that are running in Art-Net mode display only the output port status and the Art-Net port address (a number between 0 and 32767). The output port status has the same meaning as when the independent universes feature is disabled.

Output Port 1	Art-Net
Status	No DMX
UNIVERSE	37

While the port address (large number at the bottom) is being edited but has not yet been stored, a slowly blinking cursor is shown below the currently editable digit. Use the encoder to increase or decrease that digit. Push the output port button (button [1] – button [4], see page 7) to change the digit that is currently editable.

Output Port 1	Art-Net
Status	No DMX
UNIVERSE	00037

For more information about the addressing of Art-Net ports, see section Representations of Art-Net Port Addresses in the Appendix.

sACN Mode

Ports that are running in sACN mode only display the sACN universe number and the output port status. The output port status has the same meaning as when operating in Art-Net mode.

Output Port 4	sACN
Status	DMX OK
UNIVERSE	1

The sACN universe number may be in the range of 1 – 63999. While the universe (large number at the bottom) is being edited but has not yet been stored, a slowly blinking cursor is shown below the currently editable digit. Use the encoder to increase or decrease that digit. Push the output port button (button [1] – button [4], see page 7) to change the digit that is currently editable.

Output Port 4	sACN
Status	Hold
UNIVERSE	00010

Factory Presets

The *Factory Presets* menu entry of the main menu allows you to load one of the following factory defined presets:

- **Art-Net:**
 - Loads default network settings (IP address set to primary Art-Net IP address).
 - Art-Net RDM is enabled on all ports.
 - Ports 1 – 4 are configured to Art-Net universes 0 – 3 (Art-Net sub-net: 0, Art-Net net: 0).
- **Art-Net, no RDM:**
 - Same as Art-Net, RDM disabled on all ports.
- **sACN:**
 - Network is configured via DHCP.
 - Art-Net RDM is enabled.
 - Ports 1 – 4 are configured to sACN universes 1– 4
- **1,2: Art-Net – 3,4: sACN:**
 - Loads default network settings (IP address set to primary Art-Net IP address).
 - Art-Net RDM is enabled on all ports. Note: affects port 1 and 2 only while port 3 and 4 are configured to output data from sACN.
 - Ports 1 and 2 are configured to Art-Net universe 0 and 1 (Art-Net sub-net: 0, Art-Net net: 0).
 - Ports 3 and 4 are configured to sACN universe 3 and 4.
- **Art-Net, Office Network:**
 - Same as Art-Net but network is configured via DHCP.

Loading any of the presets disables independent Art-Net universes (Independent Universes, page 11).

Device Settings and Information

Address Display Mode

Under *Address Display Mode*, a selection list is presented to you with the following options:

- **Decimal:** Art-Net net, Art-Net sub-net, Art-Net or sACN universe and Art-Net sub-uni are displayed as decimal numbers.
- **Hexadecimal:** Art-Net net, Art-Net sub-net, Art-Net or sACN universe and Art-Net sub-uni are presented as hexadecimal numbers with a trailing h (e.g. F3h).

A bullet point is shown next to the currently active setting. Use the encoder wheel to select the desired setting and push [OK], to apply the setting.

Screen Saver

Under *Screen Saver*, a selection list is presented to you with the following options:

- **Enable:** Screen saver is enabled.
- **Disable:** Screen saver is disabled.

A bullet point is shown next to the currently active setting. Use the encoder wheel to select the desired setting and push [OK] to apply the setting.

Please refer to the section *Screen Saver* on page 20 for more details about the behaviour of the screen saver.

Mute LEDs

Under *Mute LEDs*, a selection list is presented to you with the following options:

- *Mute*: All status indicator LEDs of the device remain dark regardless of the device's status.
- *Unmute*: The status indicator LEDs behave as described under *Status LEDs* on page 19.

A bullet point is shown next to the currently active setting. Use the encoder wheel to select the desired setting and push [OK] in order to apply the setting.

User Input Locking

The menu item *User Input Locking* allows you to lock your device with a password to protect your device from unauthorized or accidental manipulation. When the device is locked, the user will only be able to see the Home Screen (see page 10) and the Ethernet Port Status Information (see page 19). Since the menu is unavailable while the device is locked, the Ethernet Port Status Information is only accessible via the button next to the Ethernet port.



When pressing the [OK] button from the Home Screen of a locked device, it will prompt for the password. If it is entered correctly, the device becomes unlocked and the main menu is displayed. A padlock symbol in the top right corner of the Home Screen indicates that the user input is currently locked.

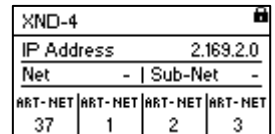

Before a device can be locked, a password must be set, and locking must be enabled.

Set Password

Choose the menu entry *Settings > User Input Locking > Set Password* to set a password. A dialog will show up that prompts for a password. Password editing works just like editing the device name, as detailed on page 12.



Once the password has been entered, XND-4 will ask you to enter the password a second time.

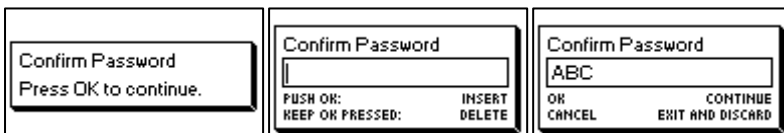

If the two entered texts match, the password is set.

Finally, after the password was successfully stored, the user will be asked whether he wants to enable password locking, if it is not already enabled.

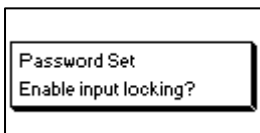

By pressing [OK], password locking is enabled. Pressing [Cancel] closes the dialog and keeps password locking disabled, but the password is set anyway.

To change the password, simply open the *Set Password* dialog again. It is not required to enter the current password before changing it.

Enable/Disable Locking

The menu entry *Settings > User Input Locking > Enable/Disable Locking* lets the user choose whether password locking is disabled or enabled. If the user requests to enable password locking and a password has already been set, the user will be asked to enter the password before password locking is enabled. If the user requests to enable password locking when no password has been set up, the user will be prompted to enter and confirm a password, before password locking is enabled.

Lock User Input

Once password locking has been enabled, the additional menu item Lock User Input will appear on the top level of the menu and under *Home > Menu > Settings > User Input Locking*. If the user activates this menu item, he will be asked whether the device should be locked. [OK] will lock the device, [Cancel] will keep it unlocked.



The device will also be locked when the screen saver becomes active or after a power cycle if locking has been enabled.

Device Information

The following information about the device is available under *Home > Menu > Device Settings > Device Information*.

Model

The device model is reported as "XND-4" for all variants of the XND-4.

Boot Software

The full version number of the boot software.

Firmware

The full version number of the firmware.

Hardware

The hardware revision.

MAC Address

The MAC address of the node's Ethernet interface.

UIDs

The RDM UIDs (unique identifiers) of the four output ports. These are numbers that unambiguously identify any RDM device. Since each output port may act as an RDM controller, each output port has assigned its own RDM UID.

Restore Default Settings

The default settings can be restored under *Home > Menu > Restore Default Settings*. In this menu, you will be asked whether you want to continue restoring all settings. Push [OK] to confirm or [Cancel] to abort.

This function will restore all settings to the defaults:

- Name: SWISSON XND-4
- Short name: XND-4
- Art-Net net: 0
- Art-Net sub-net: 0
- Art-Net RDM: Enabled on all output ports
- Independent universes: Disabled
- All outputs enabled
- Art-Net universe output 1-4: 0-3

- Failure behaviour (all outputs): Hold last look
- Merge mode (all outputs): HTP
- IP address: 2.X.Y.Z (primary Art-Net IP address)
- Netmask: 255.0.0.0
- Address display mode: Decimal
- LEDs: Unmuted
- Screen saver: Enabled
- User input locking: Disabled, password not set

Ethernet Port Status Information

This screen is reached by pressing the Ethernet port button [E], which is located right next to the Ethernet port. See *Device Overview* on page 7 for more precise information about the location of this button.

Ethernet	
Link Up	100 Mb/s
Duplex	Full
IP Address	2.169.0.18
Netmask	255.0.0.0

This screen shows the following information about the status of the Ethernet port on four lines:

- The first line below the title shows whether the link is up or down and what the current connection speed is (10 Mb/s or 100 Mb/s).
- The next line informs whether the link is full or half duplex if a link is established.
- The last two lines display the currently configured IP address and the currently configured netmask.

Status LEDs

All LEDs can be muted, in which case they stay dark independently of the device's status. The information below applies when the LEDs are not muted (unmuted). Please refer to Mute LEDs on page 17 for more information about muting and unmuting the LEDs.

Selected Port

When a port is selected, the port's status LED flashes in white for 0.1 seconds once every 0.2 seconds. The DMX output ports and the Ethernet port can be selected using the push button next to the port. Further, the DMX output ports can also be selected via the menu (*Home > Menu > Outputs > Output [1-4] > Universe*).

Not Selected DMX Output Port

If a DMX output port is not selected, the port's status LED provides the following information:

- It shows the output port status for at least 0.7 seconds every second using the following colour coding:
 - Red: Not sending DMX data, but the port is enabled.
 - Yellow: Sending last look, but did not receive an update for at least 6 seconds.
 - Green: Sending DMX data, receiving updates.
 - Black: Port is disabled / turned off.
- The LED lights up white for 0.3 seconds every second, if the node is highlighted.

Ethernet Port (Not Selected)

The status LED lights up for 0.3 seconds every second, if the node is highlighted.

On the right-hand side of the status LED, there is also a link LED, which lights up in green, if an Ethernet link has been established. Traffic is indicated by short interruptions.

Screen Saver

The OLED display will automatically turn itself off when no user input is received for 40 seconds in order to improve the durability of the product, if the screen saver is enabled. Once the display is turned off, it can be turned on again by pushing any button or by turning the encoder wheel by one unit in any direction.

The screen saver can be enabled or disabled under *Home > Menu > Device Settings > Screen Saver*, as described under Screen Saver on page 16.

Firmware Updates

Firmware updates will be provided on the product page on the Swisson website. For updating the firmware, a PC with Windows (Vista or later) and a USB A to B cable (USB printer cable) is required. Please refer to the separate documentation also provided on the product web page for details about the process of updating the product's firmware.

Technical Data

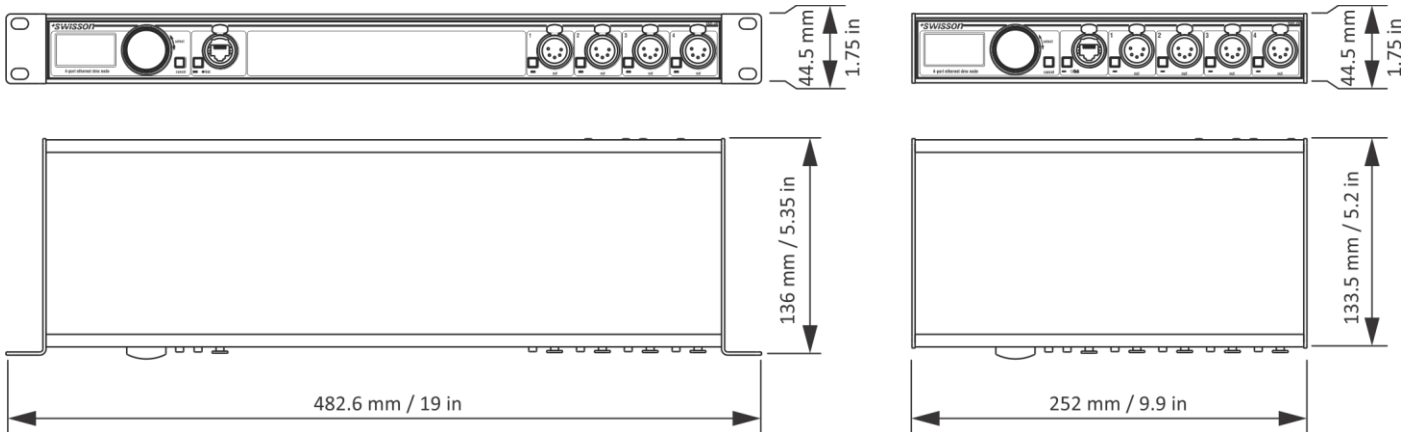

Ambient temperature -30°C...55°C (-22°F...131°F)

AC power 100 - 240 V nominal, 50/60 Hz

Typical power consumption 7 W

Ethernet 10BASE-T / 100BASE-TX, auto negotiating, auto MDI-X

Network protocols Art-Net I, II and 3, sACN (ANSI E1.31), sACN draft version (v0.2)

DMX..... ANSI E1.11

Electrical standard signal ports EIA-485

Dimensions Rack Mountable Models

Depth 136 mm (5.35 in)

Width 482.6 mm (19 in)

Height..... 44.5 mm (1.75 in)

Weight..... 1.6 kg (3.53 lb.)

Dimensions Box Models

Depth 133.5 mm (5.2 in)

Width 252 mm (9.9 in)

Height..... 44.5 mm (1.75 in)

Weight..... 1.1 kg (2.43 lb.)

Ordering Information

Standard Versions, Boxes

10 48 10	XND-4B3	4-port Ethernet DMX node, box version, 3-pin XLRs
10 48 11	XND-4B5	4-port Ethernet DMX node, box version, 5-pin XLRs
10 48 12	XND-4B8	4-port Ethernet DMX node, box version, RJ45 etherCON

Standard Versions, Rack Mountable

10 48 20	XND-4R3	4-port Ethernet DMX node, rack mountable, 3-pin XLRs
10 48 21	XND-4R5	4-port Ethernet DMX node, rack mountable, 5-pin XLRs
10 48 22	XND-4R8	4-port Ethernet DMX node, rack mountable, RJ45 etherCON

Credits

LwIP

This product includes parts of lwIP which is licenced under the BSD licence:

Copyright (c) 2001-2004 Swedish Institute of Computer Science.

All rights reserved.

Redistribution and use in source and binary forms, with or without modification, are permitted provided that the following conditions are met:

1. Redistributions of source code must retain the above copyright notice, this list of conditions and the following disclaimer.
2. Redistributions in binary form must reproduce the above copyright notice, this list of conditions and the following disclaimer in the documentation and/or other materials provided with the distribution.
3. The name of the author may not be used to endorse or promote products derived from this software without specific prior written permission.

THIS SOFTWARE IS PROVIDED BY THE AUTHOR "AS IS" AND ANY EXPRESS OR IMPLIED WARRANTIES, INCLUDING, BUT NOT LIMITED TO, THE IMPLIED WARRANTIES OF MERCHANTABILITY AND FITNESS FOR A PARTICULAR PURPOSE ARE DISCLAIMED. IN NO EVENT SHALL THE AUTHOR BE LIABLE FOR ANY DIRECT, INDIRECT, INCIDENTAL, SPECIAL, EXEMPLARY, OR CONSEQUENTIAL DAMAGES (INCLUDING, BUT NOT LIMITED TO, PROCUREMENT OF SUBSTITUTE GOODS OR SERVICES; LOSS OF USE, DATA, OR PROFITS; OR BUSINESS INTERRUPTION) HOWEVER CAUSED AND ON ANY THEORY OF LIABILITY, WHETHER IN CONTRACT, STRICT LIABILITY, OR TORT (INCLUDING NEGLIGENCE OR OTHERWISE) ARISING IN ANY WAY OUT OF THE USE OF THIS SOFTWARE, EVEN IF ADVISED OF THE POSSIBILITY OF SUCH DAMAGE.

Art-Net

Art-Net™ Designed by and Copyright Artistic Licence Holdings Ltd

Appendix

Representations of Art-Net Port Addresses

According to the Art-Net 3 specification, the address of an Art-Net port consists of three parts: The Art-Net net, sub-net and universe number. The Art-Net universe and sub-net number both have a value between 0 and 15 (4 bit). Many controllers combine these values to the sub-uni number, resulting in a value between 0 and 255 (8 bit), with the sub-net part occupying the more significant digits. Thus, the sub-uni can be calculated with the formula $16 \times \text{sub-net} + \text{universe} = \text{sub-uni}$.

The Art-Net net number was added in Art-Net 3, and has a value between 0 and 127 (7 bit). So, when working with controllers using Art-Net I or Art-Net II, the Art-Net net must be set to 0.

The Art-Net net, sub-net and universe can be combined to a 15-bit port address with values from 0 to 32767, as shown below.

Bit Digit	14	13	12	11	10	9	8	7	6	5	4	3	2	1	0
Subdivided Representation	Net (0 - 127)						Sub-Net (0 - 15)			Universe (0 - 15)					
Alternative Representation	Net (0-127)						Sub-Uni (0 – 255)								
15-bit Port Address Rep.	(0 – 32767)														

For the instances where the Art-Net net number is 0, the 15-bit port address is equivalent to the sub-uni. The table below gives an overview of the entire Art-Net 3 address space and how it is converted to a 15-bit port address.

Art-Net Address			15-bit Port Address
Net (0 - 127)	Sub-Net (0 - 15)	Universe (0 - 15)	
0	0	1	1
0	0	2	2

0	0	15	15
0	1	0	16
0	1	1	17

0	1	15	31
0	2	0	32
0	2	1	33

0	15	15	255
1	0	0	256
1	0	1	257

127	15	14	32766
127	15	15	32767
z	y	x	$z * 256 + y * 16 + x$

Art-Net II addresses

No part of this documentation may be reproduced or transmitted in any form or by any means, electronic or mechanical, including photocopying and recording, without the prior written permission of Swisson AG.

The information in this documentation is supplied without warranty of any kind, either directly or indirectly, and is subject to change without prior written notice.

Swisson, its employees or appointed representatives will not be held responsible for any damages to software, hardware, or data, arising as a direct or indirect result of the product(s) mentioned herein.

08.12.2017

SWISSON AG
Fabrikstrasse 21
CH-3250 Lyss
Switzerland

SWISSON of AMERICA Corp.
2419 East Harbor Blvd.#3
Ventura, CA 93001
U.S.A.

E-Mail: welcome@swisson.com